

KOMATSU

WA150-6

EPA Tier 3 Final Engine
Australia & New Zealand Specifications



Wheel loader

NET Horsepower
73 kW 98 HP / 2200 min⁻¹

Operating weight
7,780 – 8,125 kg

Bucket capacity
1.2 – 1.7 m³

Walk-around

NET Horsepower

73 kW 98 HP / 2200 min⁻¹

Operating weight

7,780 – 8,125 kg

Bucket capacity

1.2 – 1.7 m³

High productivity and low fuel consumption

- Useful functions given by HST
- Variable traction control system
- Maximum dumping clearance and reach

Increased reliability

- Komatsu components
- High-rigidity frames and loader linkage
- Wet multiple-disc brakes and fully hydraulic braking system



Excellent operator environment

- Pillar-less large cab
- Great rear visibility
- Best position for comfort
- Easy-to-operate loader control mono-lever

Easy maintenance

- Maintenance accessibility
- Protective guards
- Equipment management monitoring system
- Easy radiator cleaning

Safety

- Rops/fops cab (iso 3471/iso 3449)
- Rear-hinged full open cab door

Komtrax

- Complimentary remote monitoring system that provides access to specific machine data and jobsite management via an improved interface.



Photos may include optional equipment.

High productivity and low fuel consumption



Faster travel and lower fuel consumptions

High performance SAA4D95LE-5 engine

Electronic heavy duty common rail fuel injection system provides optimum combustion of fuel. This system also provides fast throttle response to match the machine's powerful tractive effort and fast hydraulic response.

Net: 73 kW 98 HP

Low emission engine

This engine is U.S. EPA Tier 3 and EU Stage 3A emissions certified, without sacrificing power or machine productivity.

Low fuel consumption

The high-torque engine and HST with maximum efficiency in the low-speed range provide low fuel consumption.

ECO indicator

The ECO indicator will inform the operator when the machine is maximising fuel efficiency.



ECO indicator

Highly Efficient HST

Electronically-controlled HST with a variable pump and 2-motor system

Komatsu HST system allow a highly efficient and powerful operation. Increasing pump capacity and variable input torque control of new electronically controlled HST pump enable the engine to run at the best speed range and reduce fuel consumption.

The efficiency of HST motors

HST provides quick travel response and aggressive drive into the pile. The variable displacement system automatically adjusts to the tractive effort demand to provide maximum power and efficiency. When high drive torque is needed, both motors are engaged to provide highest torque. Maximum rim pull can provided from zero travel speed. This combination makes the loader very aggressive and quick at digging, climbing or initiating movement. When high travel speed is needed, clutch cuts off the low speed motor to eliminate drag and achieve excellent fuel efficiency.

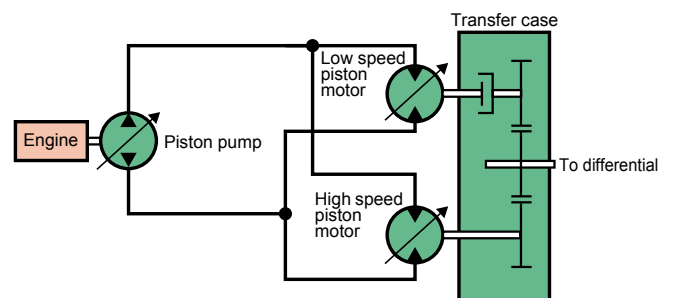

Electronically-controlled HST with variable shift control system

Full auto-shifting

Full auto shifting eliminates any gear shifting and kick-down operation to allow the operator to concentrate on digging and loading.

Variable shift control system

The variable shift control system allows setting the top speed for increased safety and precision. The operator can choose between first, second, third or fourth maximum speeds by dialing the speed range selector switch. For v-cycles, the operator can set the speed control switch to 1 or 2, which provides aggressive digging, quick response and fast hydraulics. For load and carry, select 3 or 4 which still provides aggressive digging but with much faster travel speed.

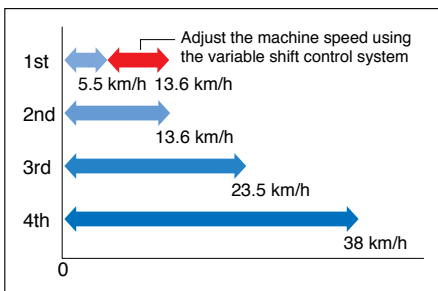

Variable and fine travel speed control

When the variable shift control switch is in 1st speed, ground speed can be adjusted between 5.5 km/h and 13.6 km/h with the fine control. This allows constant low driving speeds that are perfectly adjusted to applications such as lawn mowing or milling jobs.

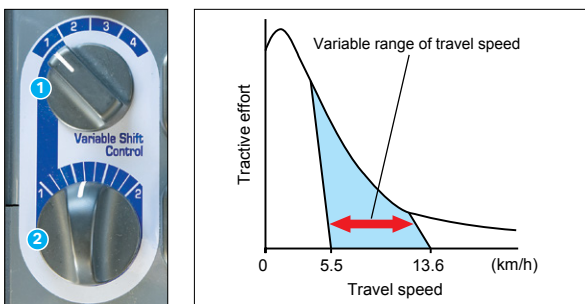

- ① Speed range selector switch
- ② Variable shift control switch

Useful functions given by HST

Self braking effect of the HST drive lines

The self braking effect of the HST drive line slows down the machine when the accelerator pedal is released. It can hold the loader in position on workable slopes, and it will be an advantage in stockpiling or ramp loading. Also it prevents uncontrolled rolling. Safety is greatly improved especially when working in confined spaces or inside industrial buildings. In addition, brake wear is practically eliminated.

Improved inching performance

Electronically controlled HST brake provides improved inching performance of the machine and demonstrates ideal braking control when the machine is travelling and working.

Accelerator pedal sensitive intelligent HST control

Finely-tuned HST control according to the accelerator pedal angle achieves variable clutch timing by machine speed and motor shift control in quick acceleration. It reduces shocks and allows smoother traveling and better energy-saving operation.



Overrun prevention system

Overrun prevention system will secure safety in downhill and protect the power train and brake components from overload. When the travel speed reaches 40 km/h, the caution lamp informs the operator to reduce the speed. When the machine descends a moderate slope (6 degrees or less), maximum travel speed is automatically limited to 40 km/h.

Notes: When the machine descends a steep slope, it is necessary to use the service brake to reduce the speed for safety.



Variable traction control system

The variable traction control system optimises the digging traction automatically depending on working condition by controlling HST pump, motor and engine. Combined with the function of torque proportioning differentials, or optional limited slip differential this system exerts the following effects.

- Facilitates operation on soft ground where the tyres of the machine are apt to slip.
- Eliminates excessive bucket penetration and reduces tyre slippage during stockpile loading to improve the work efficiency.
- Reduces tyre slippage to extend the life of tyres. Furthermore, the maximum tractive effort can be adjusted in five stages while the traction control switch is ON. This allows the operator to select the optimum tractive effort for diversified road conditions.

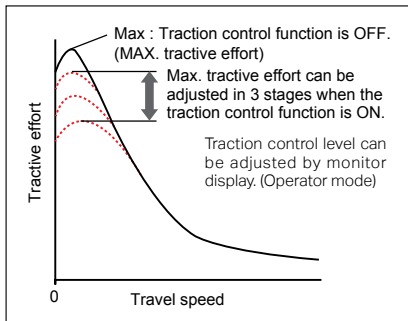

S-mode

Setting the switch to S-mode allows the machine to get the optimum driving force for operations on slippery road surfaces, like snow-removal on snow surface, resulting in reduced tyre slippage and facilitation of the operation. Unexpected tyre slippage on slippery road surface is suppressed by controlling the engine speed and HST motor when traveling at a low speed. (S-mode is effective only in forward traveling.)

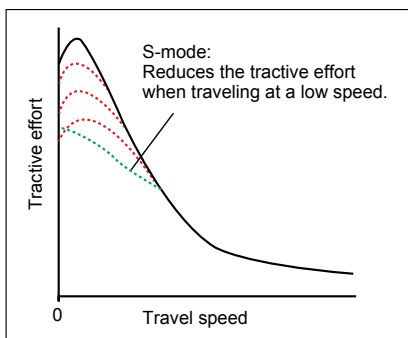

Maximum traction switch

Maximum traction switch is located on the work equipment control lever. When traction control switch is at ON position or S-mode is selected, pushing this switch temporarily cancels the setting of the traction control and increases the tractive effort to its 100% value. Then pushing the max. traction switch again or operating the F/R lever returns the tractive effort to the set value automatically. This switch is useful for operations such as piling up work where large tractive effort is required temporarily.

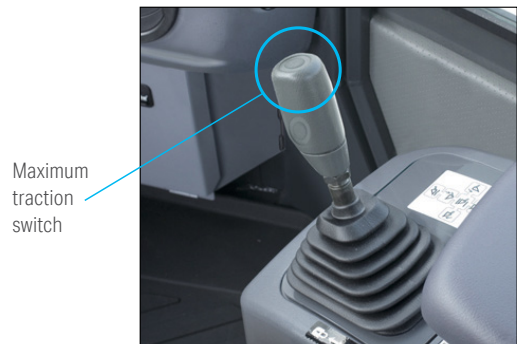
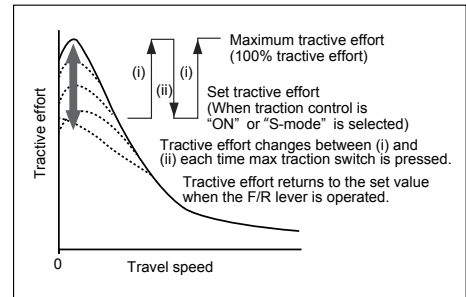

Maximum dumping clearance and reach

The long lift arms provide high dumping clearances and maximum dumping reach. The operator can even level loads on the body of a dump truck easily and efficiently.

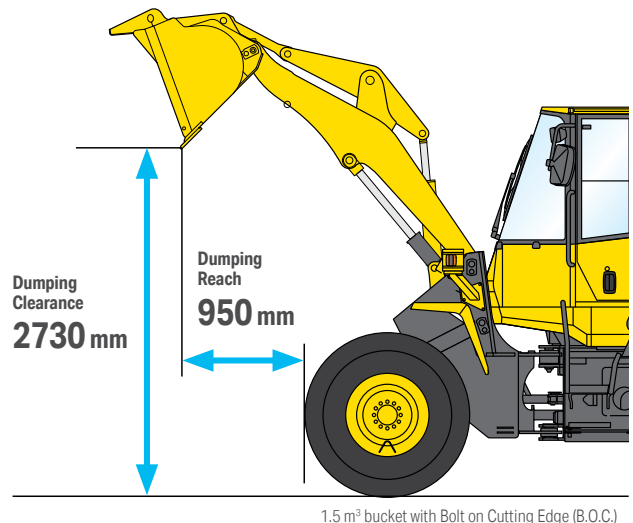

Increased reliability

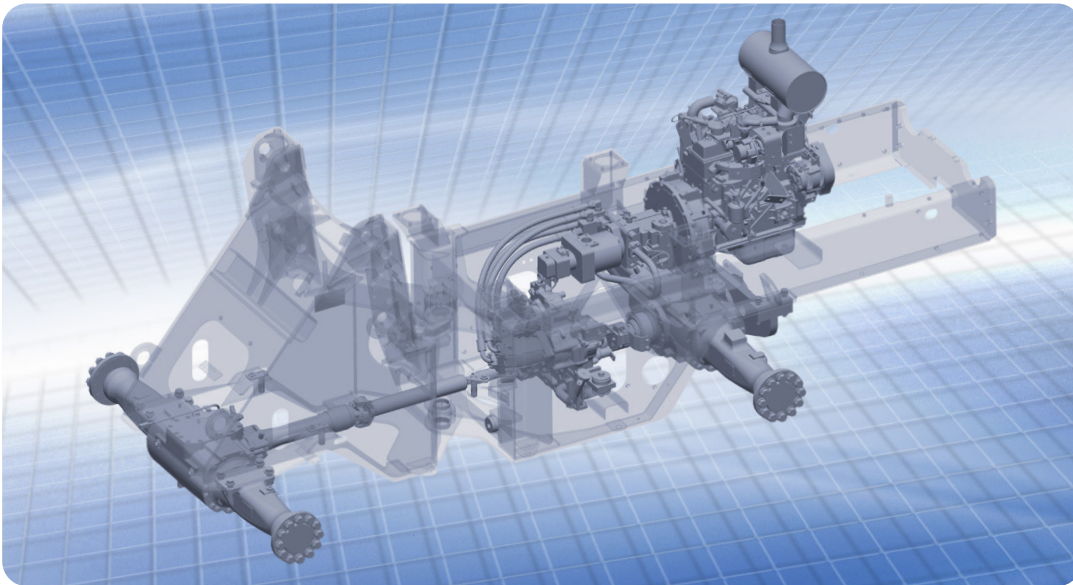

Komatsu components

Komatsu manufactures the engine, transfer case and hydraulic components on this wheel loader. Komatsu loaders are manufactured with an integrated production system under a strict quality control system.

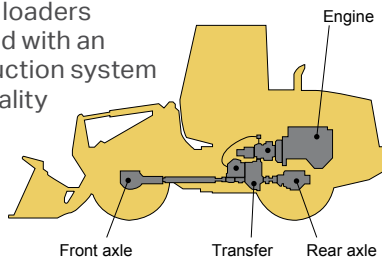

High-rigidity frames and loader linkage

The front and rear frames and the loader linkage have got more torsional rigidity to provide resistance increased to stresses. Frame and loader linkage are designed to accommodate actual working loads, and simulated computer testing proves its strength.

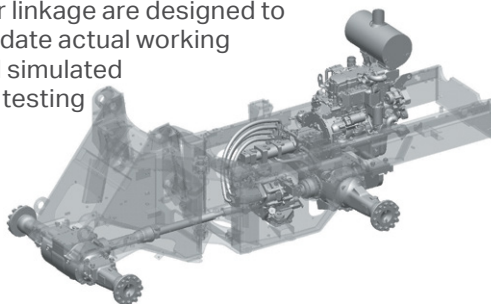

Sealed connectors

Main harnesses and controller connectors are equipped with sealed connectors providing high reliability, water resistance and dust resistance.



Wet multiple-disc brakes and fully hydraulic braking system

This system result in lower maintenance costs and higher reliability. Wet multiple-disc brakes are fully sealed. Contaminants are kept out, reducing wear and resulting maintenance. Brakes require no adjustments for wear, meaning even lower maintenance. The parking brake is also an adjustment-free, wet multiple-disc for high reliability and long life. Added reliability is designed into the braking system by the use of two independent hydraulic circuits. Provides hydraulic backup should one of the circuits fail. Fully hydraulic brakes mean no air system to bleed, or the condensation of water in the system that can lead to contamination, corrosion, and freezing.

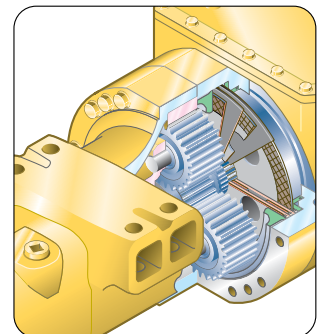
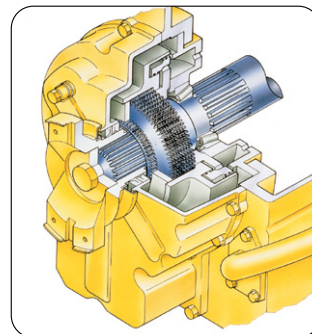

Reliable hydraulic line

Flat face-to-face O-ring seals are used to securely seal hydraulic hose connections and to prevent oil leakage.

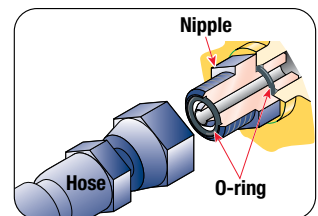

Excellent operator environment



The large space cab offers exceptional driver's comfort - comparable to a passenger car. The large, frameless window gives an unobstructed view of the bucket and tyres while the slanted rear end ensures a clear view to the rear. The low-noise designed cab with the air-cushioned seat and the fully adjustable console inside allow the operator to work comfortably and productively over long period.

Pillar-less large cab

A wide pillar-less flat glass provides excellent front visibility. The wiper arm covers a large area to provide great visibility even on rainy days. The large cab area providing maximum space for the operator. The front mounted air conditioner (A/C) was introduced to increase seat reclining and backward slide adjustment.



Great rear visibility

Centre lined muffler and air intake piping provides great rear right and left hand side visibility.

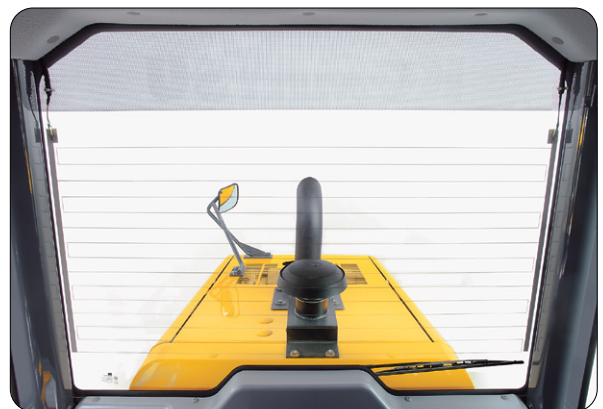

Best Position for Comfort

Tiltable steering column

The operator can tilt the steering column to provide a comfortable working position.



Adjustable wrist rest

The height of wrist rest is adjustable. It allows operators to adjust the controls to a comfortable position.



Low-noise Design

The large cab is mounted with Komatsu's unique ROPS/FOPS (ISO 3471/ISO 3449) viscous mounts. The low-noise engine, hydraulically driven fan, and hydraulic pumps are mounted with rubber cushions, and the cab sealing is improved to provide a quiet, low-vibration, dustproof with pressurising, and comfortable operating environment.

Operator's ear noise level: 72 dB(A)
Dynamic noise level (Outside): 104 dB(A)

Electronically controlled directional lever

The operator can change direction with a touch of his fingers without removing his hand from the steering wheel. Solid state electronics makes this possible.

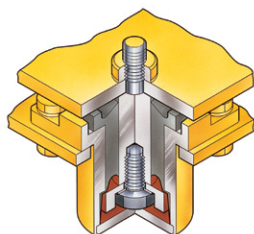

Easy-to-operate loader control mono-lever

The new mono-lever using Proportional Pressure Control (PPC) allows the operator to easily operate the work equipment, to reduce operator fatigue and to increase controllability. The adjustable wrist rest provides the operator with a variety of comfortable operating positions.

Right-side control panel

The operator can easily select the speed range, maximum travel speed in 1st, tractive effort.



- 1 Loader control mono-lever
- 2 Speed range selector switch
- 3 Variable shift control switch
- 4 Traction control switch
- 5 Maximum traction switch
- 6 Fan reverse switch

Options

12 V outlet

In addition to 24 V cigarette lighter, 12 V outlet is provided in the cab.

Electronically controlled suspension System

Electronically controlled suspension system uses an accumulator which absorbs some of the shock in the boom arm, giving the operator a much smoother ride. This reduces operator fatigue and reduces material spillage during load and carry operations. Electronically controlled suspension system operation is speed sensitive and turned off automatically below 5 km/h speed, meaning that the boom won't move during stationary digging.

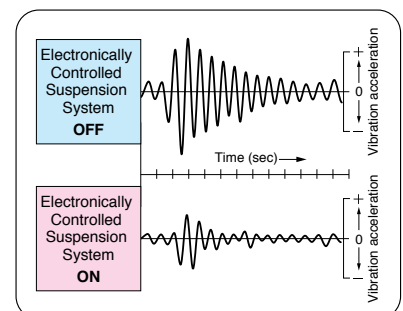

Above diagram is for illustration purpose only.

Easy maintenance



Maintenance Accessibility

Designed to save time

With long service intervals and best-in-class accessibility, the WA150-6 reduces the time and money you need to spend on maintenance. A gas spring helps the operator open and close each gull-wing side door for easy daily servicing.

Simple and convenient access to service

The service doors are designed as gull-wing doors. They allow you convenient and safe access to the daily service points from the ground.



Protective Guards

Thermal safety guards

Thermal guards for high temperature exhaust manifold are installed.



Rotating safety guards

Protective guards for rotating parts of the alternator and the air conditioner compressor are installed.



Equipment Management Monitoring System

Komatsu's new main monitor keeps the operator informed of all machine functions at a glance. The monitor is located behind the steering wheel and displays different machine functions including fluid/filter change intervals and troubleshooting memory display functions. The main gauges are analog type for easy viewing and other functions utilise lighted symbols or Liquid Crystal Display (LCD) readouts.

Maintenance control and troubleshooting functions

- **Action code display function:** If an abnormality occurs, the monitor displays action details on the character display at the bottom centre of the monitor.
- **Monitor function:** Controller monitors engine oil level, pressure, coolant temperature, air cleaner clogging, etc. If controller finds abnormalities, the error is displayed on LCD.
- **Replacement time notice function:** Monitor informs replacement time of oil and filters on LCD when replacement intervals are reached.



- 1 Engine coolant temperature
- 2 Speedometre
- 3 Fuel gauge
- 4 HST oil temperature gauge
- 5 Character display
- 6 Inspection and maintenance items pilot lamp

- **Trouble data memory function:** Monitor stores abnormalities for effective troubleshooting.

Easy Radiator Cleaning

Hydraulic driven fan with reverse rotation

If the machine is operating in adverse conditions, the operator can reverse the hydraulic cooling fan from inside the cab by pressing a switch on the control panel.

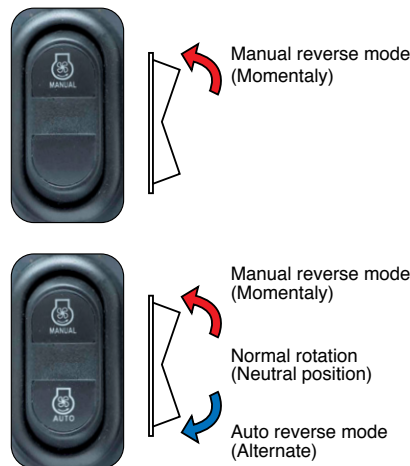

Hydraulic driven fan

Automatic reversible fan (Optional)

The engine fan is driven hydraulically and can be operated in reverse automatically. When the switch is in the automatic position, the fan revolves in reverse for 2 minutes every 2 hours intermittently (default setting).

Side-by-side cooling unit

The cooling system is isolated from the engine by a bulkhead to provide more efficient cooling and low noise. The radiator, air-to-air cooler and oil cooler are mounted side-by-side for more efficient cooling and easy cleaning. A fully-opening, gas spring assisted rear grille gives the operator excellent access to the swing-out fan and coolers.



Swing-out fan

Side-by-side cooling unit

Safety



ROPS/FOPS Cab

The ROPS/FOPS cab is standard for operator's safety.

A wide pillar-less flat glass provides excellent front visibility, and a heated rear window provides excellent rear visibility in cold and freezing weather conditions.



ROPS (ISO 3471) : Roll-over Protective Structure

FOPS (ISO 3449) : Falling Objects Protective Structure

Rear-hinged Full Open Cab Door

The cab door hinges are installed to the rear side of the cab providing a large opening angle for the operator to enter and exit. The steps are designed like a staircase, so that the operator can get on and off the cab easily.



Alternate Exit of Cab

The door on the right side of the cab is provided as an alternate exit for use when the operator cannot get out through the door on the left side.

Other Safety Features

Two independent lines brake system

Added reliability is designed into the braking system by the use of two independent hydraulic circuits, providing hydraulic backup should one of the circuits fail.

Secondary steering (Optional)

If the steering pump is disabled, a secondary steering pump provides hydraulic flow.

Battery disconnect switch (Optional)

The battery disconnect switch is located in the right side battery box. This can be used to disconnect power when performing service work on the machine.

Komtrax Equipment Monitoring

Get the whole story with

KOMTRAX®

What

- KOMTRAX is Komatsu's remote equipment monitoring and management system. KOMTRAX continuously monitors and records machine health and operational data.
- Information such as fuel consumption, utilisation, and a detailed history lowering owning and operating cost.

Who

- KOMTRAX is standard equipment on all Komatsu construction products.

When

- Know when your machines are running or idling and make decisions that will improve your fleet utilisation.
- Detailed movement records ensure you know when and where your equipment is moved.
- Up to date records allow you to know when maintenance is due and help you plan for future maintenance needs.

Where

- KOMTRAX data can be accessed virtually anywhere through your computer, the web or your smart phone.
- Automatic alerts keep fleet managers up to date on the latest machine notifications.

Why

- Knowledge is power – make informed decisions to manage your fleet better.
- Knowing your idle time and fuel consumption will help maximise your machine efficiency.
- Take control of your equipment – any time, anywhere.



KOMTRAX

For construction and compact equipment.

KOMTRAX Plus

For production and mining class machines.

Specifications

Engine

Model	Komatsu SAA4D95LE-5
Type	Water-cooled, 4-cycle
Aspiration	Turbocharged, aftercooled
Number of cylinders	4
Bore	95 mm
Stroke	115 mm
Piston displacement	3.26 ltr
Horsepower:	
SAE J1995	Gross 74 kW 99 HP
ISO 9249/SAE J1349*	Net 73 kW 98 HP
Rated rpm	2200 min ⁻¹
Governor	All-speed, electronic
Fan drive method for radiator cooling	Hydraulic
Fuel system	Direct injection
Lubrication system:	
Method	Gear pump, force-lubrication
Filter	Full-flow type
Air cleaner	Dry type with double elements and dust evacuator, plus dust indicator

*Net horsepower at the maximum speed of radiator cooling fan is 71 kW 95 HP U.S. EPA Tier 3 and EU Stage 3A emissions certified

Transmission

Type	Hydrostatic, 1 pump, 2 motors with speed range select	
Travel speed (for both forward and reverse)		
1st	5.5 - 13.6 km/h	5.3 - 13.0 km/h
2nd	13.6 km/h	13.0 km/h
3rd	23.5 km/h	22.4 km/h
4th	38.0 km/h	36.2 km/h
	Measured with 17.5-25 tyres	Measured with 16.9-24 tyres

Axles and final drives

Drive system	Four-wheel drive
Front	Fixed, semi-floating
Rear	Centre-pin support, semi-floating, 16° total oscillation
Reduction gear	Spiral bevel gear
Differential gear	Torque proportioning
Final reduction gear	Planetary gear, single reduction

Brakes

Service brakes	Hydraulically actuated, wet multiple-disc brakes actuate on four wheels
Parking brake	Wet, multiple-disc brake on transfer output shaft
Secondary brake	Parking brake is commonly used

Steering system

Type	Full-hydraulic power steering
Steering angle	38° each direction (40° to end stop)
Minimum turning radius at the centre of outside tyre	4675 mm

Hydraulics

Steering system	
Hydraulic pump	Gear type pump
Capacity	108 ltr/min at rated rpm
Relief valve setting	18.6 MPa 190 kgf/cm ²
Hydraulic cylinders	
Type	Double-acting, piston type
Number of cylinders	2
Bore x stroke	35 mm x 375 mm
Loader control	
Hydraulic pump	Gear type pump
Capacity	54 ltr/min
Relief valve setting	20.6 MPa 210 kgf/cm ²
Hydraulic cylinders:	
Type	Double-acting, piston type
Number of cylinders—bore x stroke	
Lift cylinder	2- 110 mm x 628 mm
Bucket cylinder	1- 110 mm x 452 mm
Control valve	2-spool type
Control positions:	
Boom	Raise, hold, lower, and float
Bucket	Tilt-back, hold, and dump
Hydraulic cycle time (rated load in bucket):	
Raise	6.0 s
Dump	1.1 s
Lower (Empty)	3.6 s

Service refill capacities

Cooling system	14.6 ltr
Fuel tank	133.0 ltr
Engine	11.5 ltr
Hydraulic system	47.0 ltr
Axle front	14.0 ltr
Axle rear	14.5 ltr
Torque converter and transmission	3.9 ltr

Bucket Selection Guide

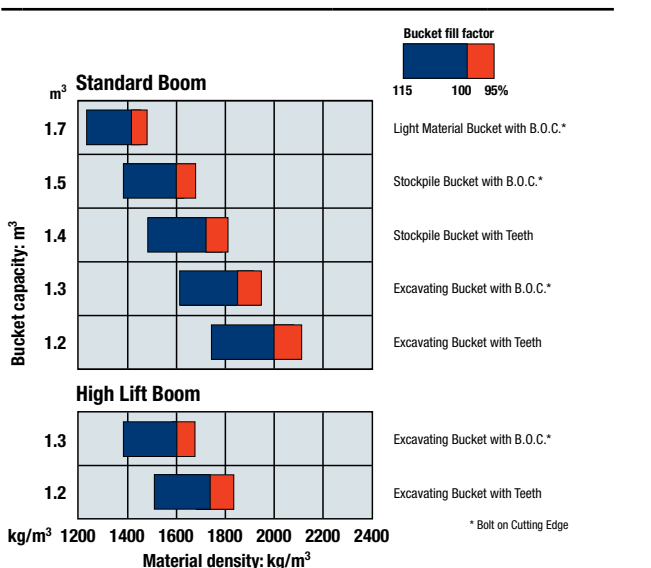

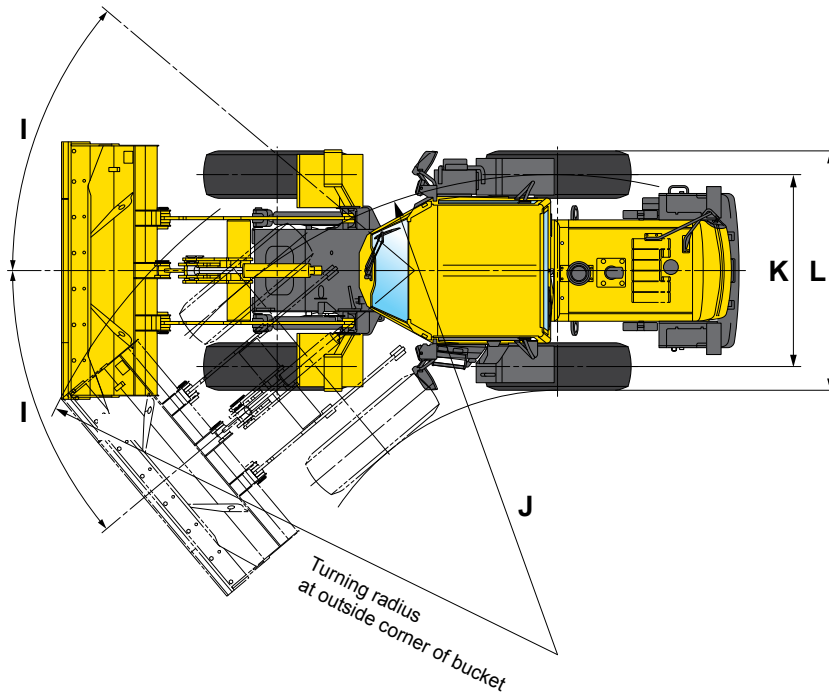
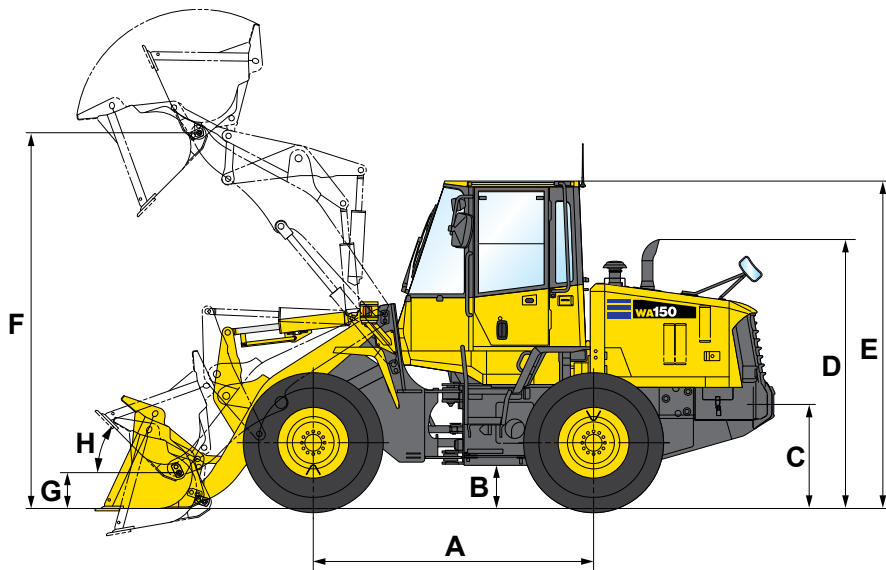

Dimensions

	Standard Boom	High Lift Boom
A Wheelbase	2600 mm	
B Ground clearance	425 mm	
C Hitch height	825 mm	
D Overall height, top of stack	2520 mm	
E Overall height, top of ROPS cab	3060 mm	
F Hinge pin height, maximum height	3510 mm	4045 mm
G Hinge pin height, carry position	355 mm	520 mm
H Maximum tilt back angle, carry position	45°	45°
I Steering angle, each direction	38°	
J Turning radius, centre of outside tyre	4675 mm	
K Tread	1780 mm	
L Width over tyres	2220 mm	

Measured with 17.5-25-12PR (L-2) tyres

Specifications

Dimensions

	Stockpile Bucket		Standard Boom Excavating Bucket		Light Material Bucket	High Lift Boom Excavating Bucket	
	BOC*	Teeth	BOC*	Teeth	BOC*	BOC*	Teeth
Bucket capacity: heaped	1.5 m ³	1.4 m ³	1.3 m ³	1.2 m ³	1.7 m ³	1.3 m ³	1.2 m ³
Bucket capacity: struck	1.25 m ³	1.2 m ³	1.1 m ³	1.05 m ³	1.5 m ³	1.1 m ³	1.05 m ³
Bucket width	2390 mm	2390 mm	2390 mm	2390 mm	2390 mm	2390 mm	2390 mm
Bucket weight	595 kg	540 kg	575 kg	520 kg	660 kg	575 kg	520 kg
Dumping clearance, maximum height and 45° dump angle [^]	2730 mm	2670 mm	2770 mm	2710 mm	2655 mm	3335 mm	3275 mm
Reach at maximum height and 45° dump angle [^]	950 mm	1000 mm	910 mm	960 mm	1025 mm	1005 mm	1060 mm
Reach at 2130 mm clearance and 45° dump angle	1380 mm	1395 mm	1355 mm	1375 mm	1415 mm	1840 mm	1865 mm
Reach with arm horizontal and bucket level	2025 mm	2100 mm	1965 mm	2040 mm	2130 mm	2405 mm	2485 mm
Operating height (fully raised)	4655 mm	4655 mm	4585 mm	4585 mm	4735 mm	5125 mm	5125 mm
Overall length	6285 mm	6365 mm	6225 mm	6305 mm	6390 mm	6805 mm	6885 mm
Loader clearance circle (bucket at carry, outside corner of bucket)	10755 mm	10800 mm	10730 mm	10775 mm	10785 mm	11250 mm	11310 mm
Digging depth: 0°	65 mm	75 mm	65 mm	75 mm	65 mm	110 mm	115 mm
Digging depth: 10°	230 mm	250 mm	220 mm	240 mm	245 mm	260 mm	280 mm
Static tipping load: straight	6745 kg	6800 kg	6785 kg	6840 kg	6650 kg	5195 kg	5260 kg
Static tipping load: 40° full turn	5870 kg	5920 kg	5905 kg	5955 kg	5790 kg	4520 kg	4575 kg
Breakout force	7400 kg	6780 kg	8010 kg	7290 kg	6530 kg	6665 kg	6065 kg
Operating weight	7850 kg	7795 kg	7835 kg	7780 kg	7920 kg	8125 kg	8070 kg

*BOC = Bolt-on Cutting Edge

[^]At the end of tooth or Bolt-on Cutting Edge. All dimensions, weights, and performance values based on SAE J732c and J742b standards. Static tipping load and operating weight shown include lubricant, coolant, full fuel tank, ROPS cab, and operator. Machine stability and operating weight affected by counterweight, tyre size, and other attachments. Apply the following weight changes to operating weight and static tipping load.

Standard equipment

- 2-spool valve for boom and bucket controls
- Air conditioner
- Alternator, 60 A
- Auto shift transmission with mode select system
- Back-up alarm
- Batteries, 2 x 12 V/92 Ah
- Bucket positioner
- Cigarette lighter (24 V) and ashtray
- Counterweight
- Engine shut-off system, electric
- Engine, Komatsu SAA4D95LE-5 diesel
- Floor mat
- Front & rear window washer and wiper
- Fuel pre-filter with water separator
- Hydraulic driven fan with reverse rotation
- Hydraulic oil cooler
- Lift cylinders and bucket cylinder
- Lights
 - 4 front, 2 rear
 - Back up
 - Turn signal with hazard
- Loader linkage with standard lift boom
- Main monitor panel with Equipment Management Monitoring System
- PPC hydraulic control, mono lever
- Radiator mask, lattice type
- Rear heated glass (Electric)
- Rear under view mirror
- Rear view mirror for cab
- ROPS/FOPS (ISO 3471/ISO 3449) cab
- Seat belt
- Seat, rigid type with reclining
- Service brakes, wet multiple-disc type
- Starting motor, 24 V/5.5 kW
- Steering wheel, tilttable
- Sun visor
- Transmission (Hydrostatic with speed range select), automatic
- Tyres (17.5-25-12PR, L-2 tubeless)
- Wet disc parking brake

Optional equipment

- 12 V outlet
- 3-spool valve
- Additional counterweight
- AM/FM radio
- AM/FM stereo radio cassette
- Battery disconnect switch
- Bolt on Cutting Edges (B.O.C.)
- Boom kick-out
- Bucket teeth (Bolt-on type)
- Deluxe suspension seat
- Electronically Controlled Suspension System
- Engine pre-cleaner with extension
- Fire extinguisher
- Front fenders
- High lift boom
- Hydraulic driven fan with automatic reverse rotation
- Limited slip differential (Front & rear)
- Ordinary spare parts
- Power train guard
- Rear full fenders
- ROPS (ISO 3471) canopy
- Secondary steering (SAE)
- Tool kit
- Vandalism protection kit

Buckets and attachments

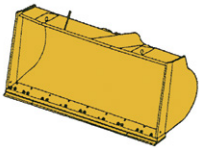
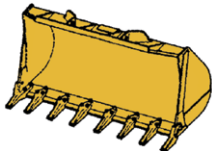
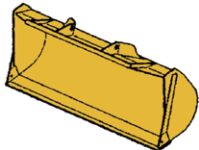
Buckets		
Type	Feature	Image
Stockpile Bucket	This bucket is used for loading stockpile products, such as crushed rock and construction materials.	
Excavating Bucket	This bucket is used for excavating and loading blasted rock on rock crushing job sites, or for excavating natural ground.	
Loose / Light Material Bucket	It has a flat-blade, straight cutting edge, and provides superior rigidity and wear resistance.	

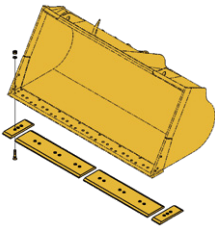
Cutting Edges and Teeth		
Type	Feature	Image
Cutting Edges	This edge is made for use in loading loose sand and soil, or for loading stockpiled materials. It is bolted to the leading edge of stockpile buckets and may be detached and reversed. The cutting edges are manufactured from especially heat treated, high tension steel, and since they are reversible, both edges can be used. This effectively doubles their working life.	<p>Bolt on Cutting Edges (B.O.C.)</p> 

Weight / Dimensions

Tyres/Attachments	Change in operating weight	Change in tipping load straight	Change in tipping load full turn	Width over tyres	Ground clearance	Change in vertical dimensions
17.5-25-12PR (L-2)	0 kg	0 kg	0 kg	2220 mm	425 mm	0 mm
16.9-24-10PR (L-2)	-150 kg	-110 kg	-95 kg	2250 mm	400 mm	-25 mm
15.5-25-8PR (L-2)	-140 kg	-100 kg	-90 kg	2180 mm	390 mm	-35 mm
Install ROPS (ISO 3471) Canopy (Instead of Cab)	-300 kg	-270 kg	-245 kg			
Install additional counterweight	50 kg	270 kg	235 kg			

Product designs, specifications and/or data in this document are provided for informational and illustrative purposes only and are not warranties of any kind. Product designs and/or specifications may be changed at any time without notice. Any applicable warranties that may be provided by Komatsu for the products and services are available on request.

Komatsu and other trade marks and service marks used herein are the property of Komatsu Ltd., Komatsu Australia Pty Ltd, Komatsu America Corp., Komatsu Mining Corp., or one of their affiliates, or the respective owners or licensees.

KOMATSU

[komatsu.com.au](https://www.komatsu.com.au)

[komatsu.co.nz](https://www.komatsu.co.nz)

