

KOMATSU

2300XPC

Electric Mining Shovel – AC Drive
Product Overview

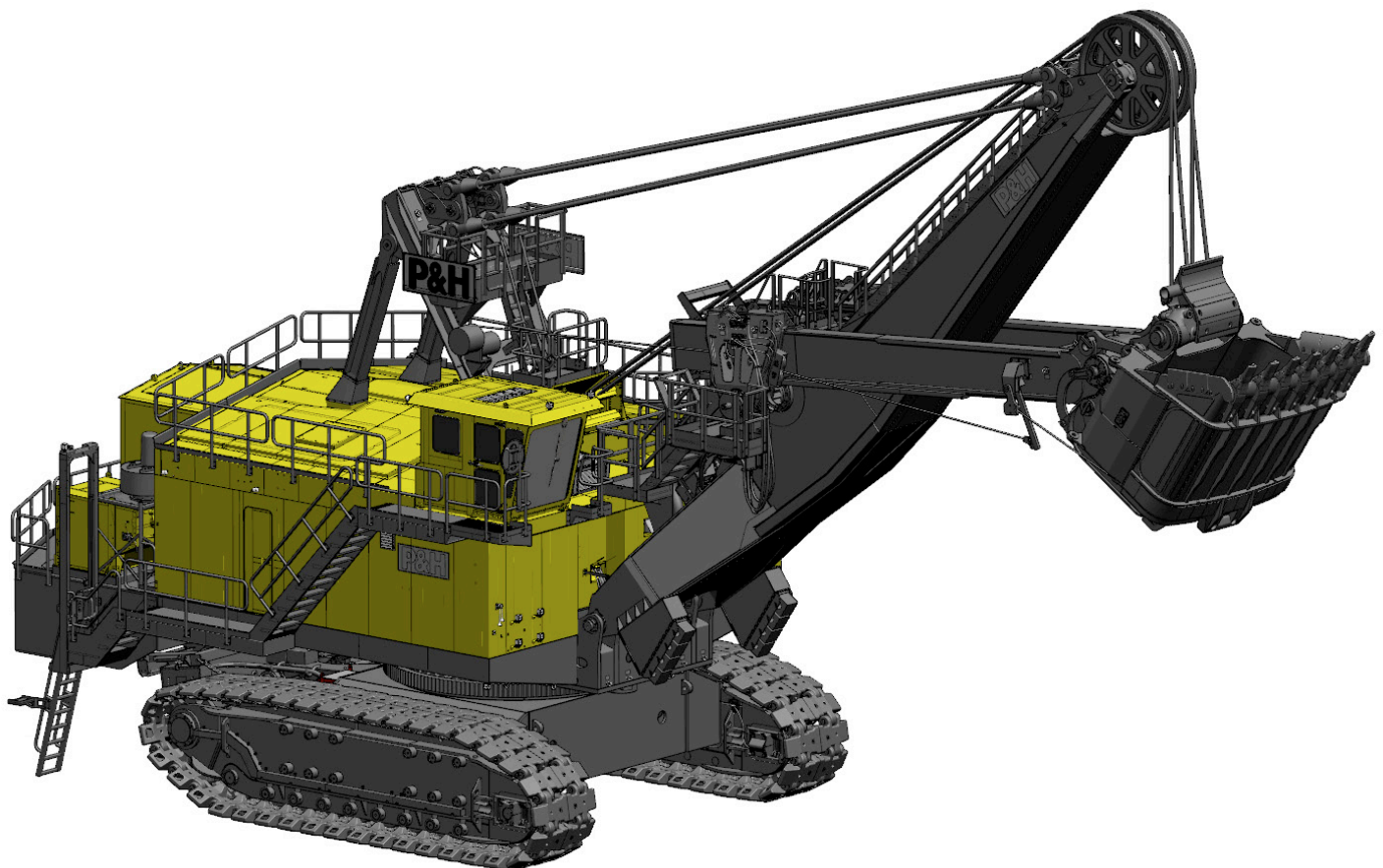

P&H

P&H 2300XPC AC Shovel building on proven success

Mine operations and maintenance managers demand the best from their loading tools. For this reason, Komatsu Mining has been the electric mining shovel market share leader and preferred equipment supplier to the world's toughest mining environments for over 100 years.

Komatsu is proud to offer the **P&H 2300XPC AC** electric mining shovel. The P&H shovel line is combining its solid reputation of reliability with the proven Centurion electrical control system, industry leading IGBT AC technology, rugged structures and the industry's leading direct field service and support network to set the industry standard for electric mining shovels.

Increases in availability and productivity ultimately lead to the lowest cost per ton and the most efficient ultra-class loading tool available in the industry today. P&H shovels dig deeper into the realms of productivity, safety and reliability with greater control, comfort and consistency.



Proven performance

P&H electric shovels have been exceeding customer requirements and expectations since 1920:

- Up to 3% faster cycle times
- Up to 2.5% increase in availability
- Up to 5% increase in productivity

Providing our customers:

- Low total cost of ownership
- High productivity
- Excellent machine reliability and durability

We set the industry standard for electric mining shovels

A closer look

The P&H 2300XPC AC features:

- IGBT AC technology
- Dual planetary propel
- Proven steel structures



The P&H performance edge

Attachment of choice for the world's toughest applications

- Twin-leg dipper handle – Stable dipper trajectory, faster cycle times, higher productivity
- Rack and pinion crowd – Less maintenance, all weather performer
- Optima dippers – Mine-matched dippers with optimized pitch braces for precise rake angles

Technology

- Centurion electrical control system – Superior performance, monitoring and data integration capabilities
- Universal shovel interface – Send and receive data with any mine management system
- PreVail remote health management – Real time machine health and performance management

Operator cab

Performance and comfort have been optimized with:

- Smart ergonomics
- Clear sight lines
- Easy access to command and control functions
- Access to key data on machine health and performance provided by Centurion electrical control system

Smart Solutions

Our smart connected products and systems, advanced analytics and direct services are integrated together and customized to solve our customers' toughest challenges:

- Service products and consumables
- Machine assembly and rebuild
- Component exchange programs
- Life cycle management
- Genuine OEM parts
- Prognostics and remote health management

Komatsu Mining is the worldwide leader in electric mining shovels. The P&H 2300XPC AC sets the standard in performance and productivity.

- Designed for *severe-duty* digging and loading
- Years of experience in building rugged, reliable equipment
- Extensive collaboration with customers and our partner ABB during development

We are driven by achieving the lowest total cost of ownership for our customers:

- Quality components
- Focus on machine availability and productivity
- Heavy-duty structures
- Komatsu Mining field support



P&H 2300XPC Electric Mining Shovel – AC Drive

General Specifications

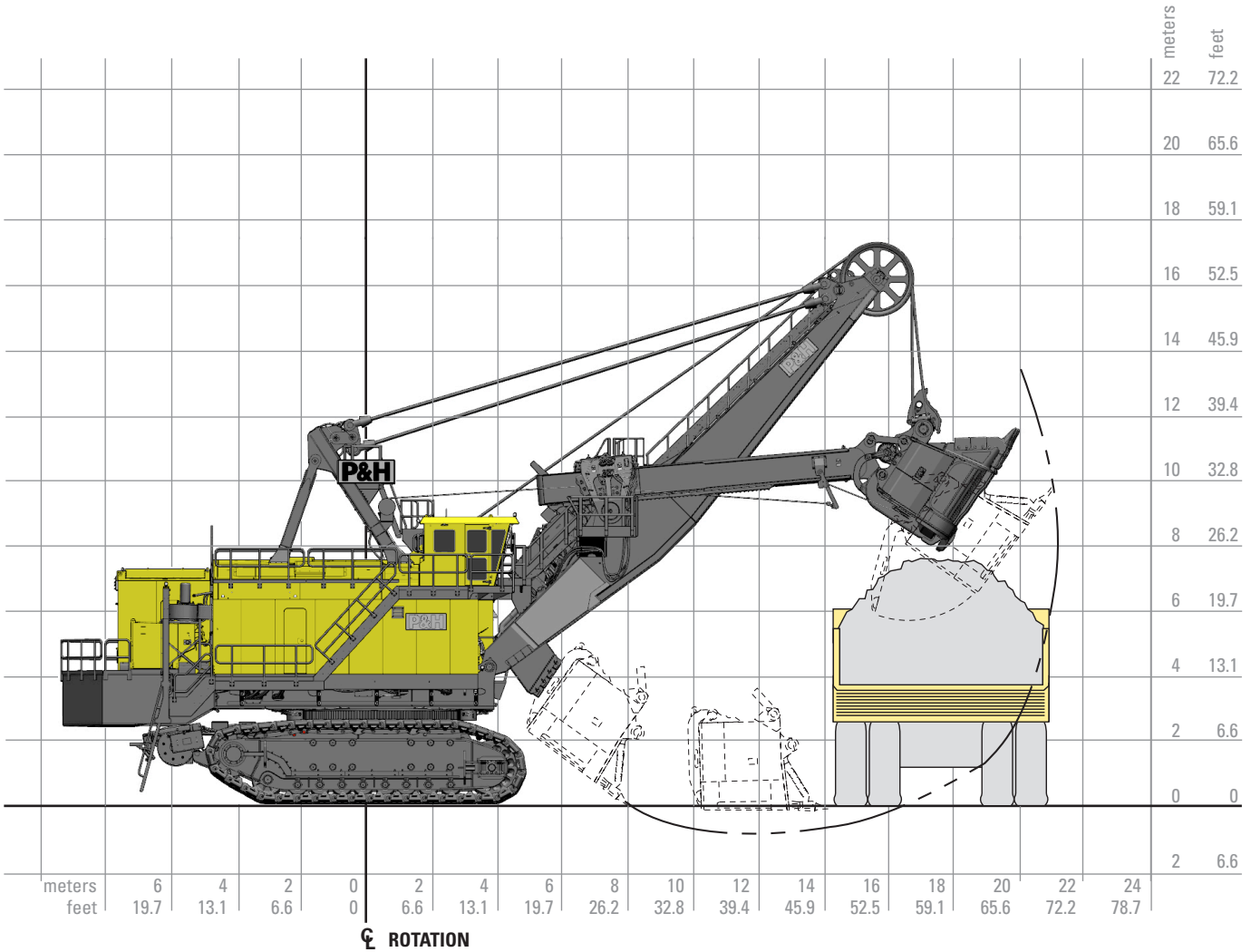

Working ranges (50 st / 33 yd ³ shown)		
Height of cut	13.8 m	45 ft 3 in
Radius of cut	20.9 m	68 ft 7 in
Dumping height* (door open)	8.5 m	28 ft 0 in
Floor level radius	14.6 m	47 ft 11 in
Tail swing radius	10.0 m	32 ft 10 in
Operator eye level	7.9 m	26 ft 0 in

*Height shown with bail-type dipper. Heights will be greater with bail-less or compact-bail dippers. Actual dumping height can be greater than door clearance height.

Capacity	40 st		50 st	
	Nominal payload*	36.3 mt	40 st	45.4 mt
Nominal dipper capacity SAE struck	16.1-22.5 m ³	19.2-26.4 yd ³	18.3-25.5 m ³	24.0-33.0 yd ³
Rated suspended load	81.6 mt	90 st	96 mt	106 st
Optimum truck size (218 mt (240 st) truck shown)	109-218 mt	120-240 st	109-218 mt	120-240 st

*Payload and dipper capacity are dependent on many factors.
Contact Komatsu Mining for an analysis of your specific application.

Power requirements

Supply voltage*	4,160 or 7,200V 3 Phase, 60 Hz	3,300, 5,000, 6,000 or 6,600 3 Phase, 50 Hz
Supply transformer	(minimum) 2,000 kVA	
Minimum short circuit VA available at shovel	16 MVA	

*Voltage per customer requirements

Dipper and dipper trip

Optima dippers combine consistent productivity with high durability and maintainability. Dippers are configured to mine specific conditions and capacity requirements from a variety of combinations of body and lip designs, as well as other unique Komatsu technologies. Specific wear packages and GET styles can be cooperatively specified.

Adjustable-torque electric motor with geared drive unit for reliable trip and slack take-up operation.

Electrical control

Centurion supervisory controller provides direct integrated communication with motor drives giving precise motor control and fast cycle times. Real-time multi-tasking capability allows for optimal machine logic sequencing, monitoring and control.

Centurion I/O system uses 'Profibus' communication protocol for seamless integration of all shovel subsystems and future expandability. Low-voltage 24V DC I/O drop points feature open and short circuit detection for improved diagnostics and troubleshooting.

Centurion information system's enhanced Graphical User Interface (GUI) features intuitive, icon-based screens to display vital information such as shovel status, troubleshooting information, and optional production monitoring data and operator feedback

P&H digital AC drive provides precise, reliable, solid state power to the main motion motors.

Electrical control systems

The electrical drive system is comprised of a multi drive platform, sharing a common DC bus between the IGBT Supply Unit (ISU) and the motor drive Inverter Units (INU). The fully regenerative ISU controls the power flow to and from the shovel, maintaining a unity power factor with extremely low harmonic content. The fully regenerative INU controls the power flow to and from the individual AC motors.

P&H AC fast response main machinery motors

		40 st	50 st
Hoist motor (two used)	Continuous rating @ 500 volts	Total 1,089 kW / 1,460 hp	Total 1,089 kW / 1,460 hp
	Peak developed power	1,161 kW / 1,557 hp	1,450 kW / 1,944 hp
Swing motor (two used)	Continuous rating @ 500 volts	Total 507 kW / 680 hp	Total 507 kW / 680 hp
	Peak developed power	688 kW / 922 hp	617 kW / 828 hp
Crowd motor (one used)	Continuous rating @ 500 volts	Total 272 kW / 365 hp	Total 272 kW / 365 hp
	Peak developed power	374 kW / 501 hp	450 kW / 604 hp
Propel motor (two used)	Continuous rating @ 500 volts	Total 328 kW / 440 hp	Total 328 kW / 440 hp
	Peak developed power	557 kW / 747 hp	684 kW / 918 hp

Swing

Two modular planetary gear cases and a single piece forged swing gear transmit torque for fast cycle times.

Spring-set air release disc brakes – one per motor.

Propel

Dual propel arrangement. Two planetary gear cases independently transmit torque to the drive sprockets, producing the tractive effort required for fast, efficient propel and positioning operations.

P&H drive system with heavy duty cast crawler shoes.

Spring-set air release disc brakes – one per motor.

Crowd

Powerband V-belt drive between motor and gear case absorbs shock loads.

First and second reduction gearing in enclosed gear case for reliable splash lubrication, ease of maintenance, and extended component life.

Twin-leg dipper handle with torsion box and rack and pinion drive has inherent stability in the bank for optimal digging.

Spring-set air release disc brake.

Hoist

Splash lubricated enclosed gearcase with lube directed to all bearings. Hoist case filtration system provided.

Large 56" diameter hoist drum for extended rope bending life. Ferrule becket system and dual electric tuggers are standard for efficient rope change.

Spring-set air release disc brakes – one per motor.

Cable data

Hoist (wire rope)	57 mm	2.25 in dia
Suspension (bridge strand)	83 mm	3.25 in dia
Dipper trip (wire rope)	16 mm	0.63 in dia

Overall dimensions

A	Width	10.5 m	34 ft 6 in
B	Length	14.2 m	46 ft 7 in
C	Height over gantry	11.8 m	38 ft 9 in
D	Width of crawler shoes	1,397 mm 1,778 mm	55 in 70 in
E	Width of crawlers (55")	8.8 m	28 ft 10 in
F	Length of crawlers	10.0 m	32 ft 8 in
G	Ground clearance	0.8 m	2 ft 8 in
H	Height — ground to bottom of counterweight slabs	2.4 m	7 ft 10 in

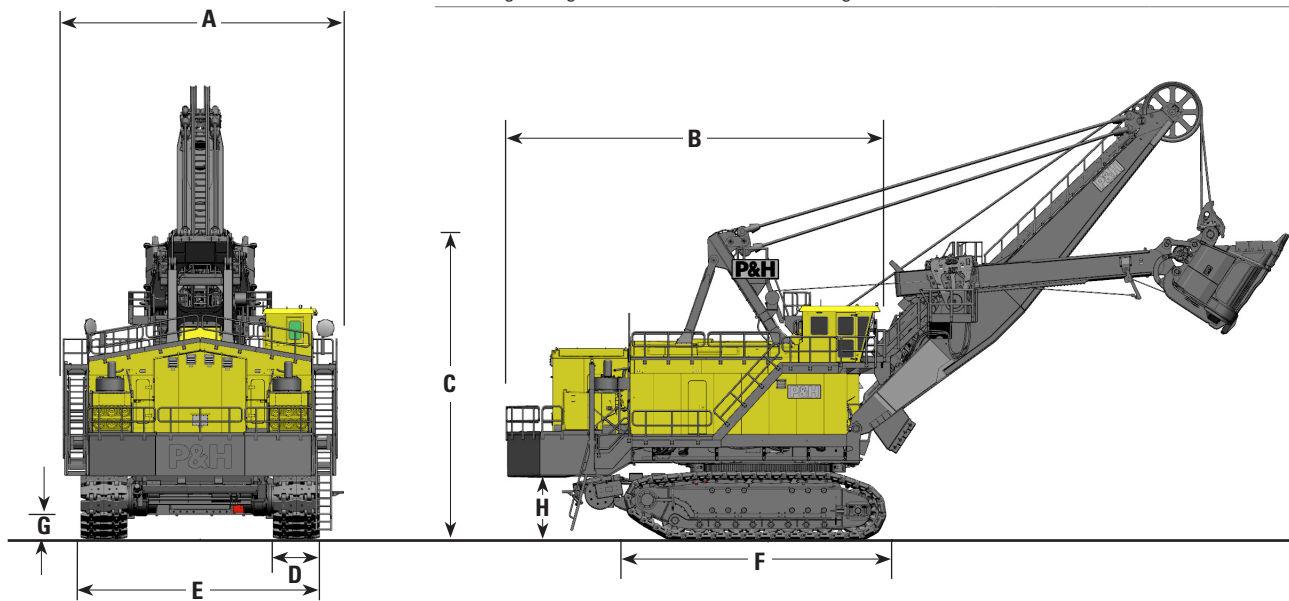

Machinery deck plan

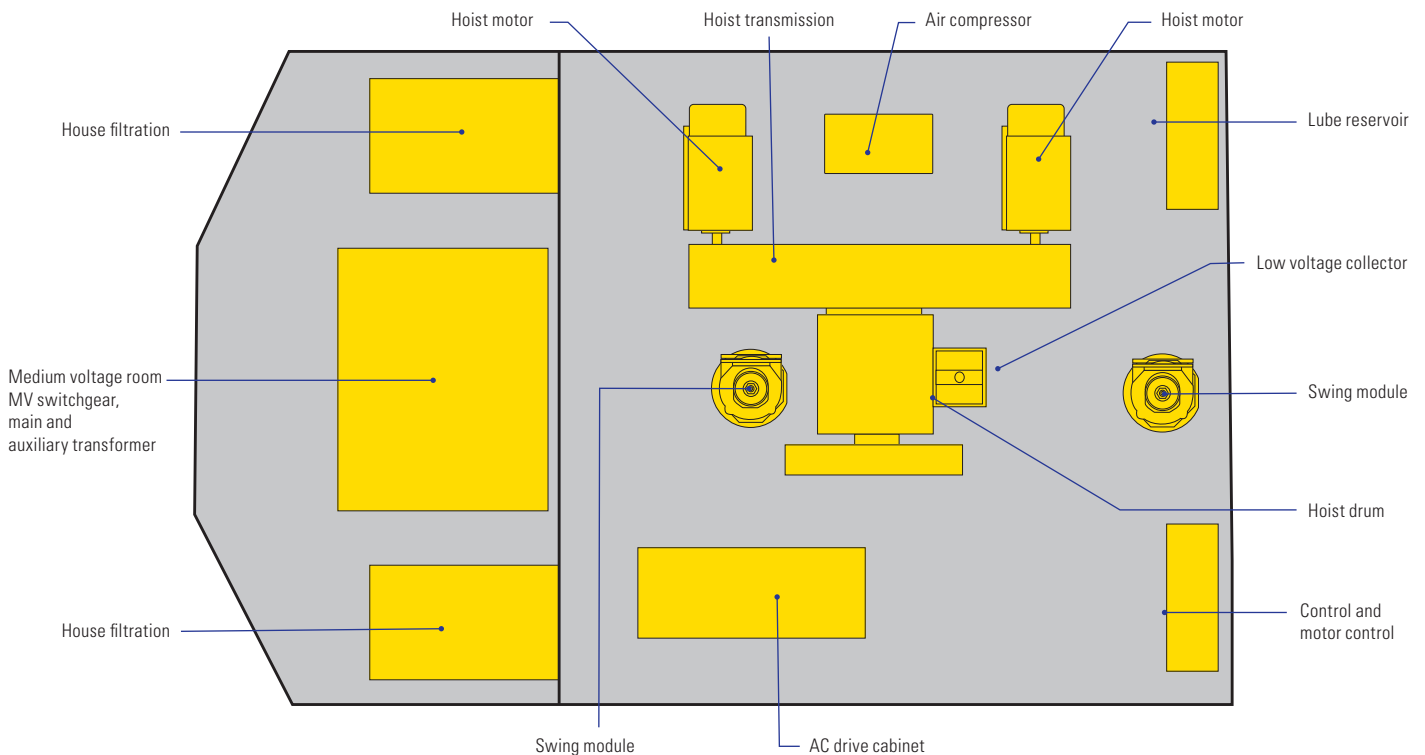

Ground pressure and weight

Bearing area – ground pressure

	40 st		50 st	
Standard:				
Crawler bearing pressure 55" shoes / 1,397 mm	344.7 kPa	50 psi	353.7 kPa	51.3 psi
Crawler bearing area 55" shoes / 1,397 mm	21.3 m ²	33,020 in ²	21.3 m ²	33,020 in ²
Optional:				
Crawler bearing pressure 70" shoes / 1,778 mm	271.7 kPa	39.4 psi	278.5 kPa	40.4 psi
Crawler bearing area 70" shoes / 1,778 mm	27.11 m ²	42,025 in ²	27.11 m ²	42,025 in ²

Weights – approximate*

Working weight (with dipper, approx. wt.)

55" shoes / 1,397 mm	748,971 kg	1,651,200 lb	767,615 kg	1,692,300 lb
70" shoes / 1,778 mm	751,240 kg	1,656,200 lb	769,883 kg	1,697,300 lb
Counterweight (punchings)**	123,830 kg	273,000 lb	140,160 kg	309,000 lb

* All weights subject to 5% variation.

** To be furnished by customer.

Features and customization

The P&H 2300XPC is built with several features to enhance safety, reliability, and productivity over the lifecycle of the operation.

- Automatic lubrication and compressed air systems with advanced diagnostic and control
- Automatic boom soft setdown system (ABSS) and boom profile protection envelope to help prevent excessive loading to the attachment during operation
- Anti-swing-in-bank system to reduce excessive side loading on handle and attachment
- Remote hoist control pendant and hoist rope winch to assist in safe and efficient rope changeouts
- AirScrubPro cartridge-based air filtration and pressurization system removes particles as small as 0.2 microns: clean, properly ventilated, and pressurized air enhances machine performance

The shovel has multiple options for local and minesite specific conditions in the following areas:

- Climate control
- Technology and software
- Maintenance systems



Contact a Komatsu Mining service representative for more information on the P&H 2300XPC electric mining shovel or visit <https://mining.komatsu>

Product designs, specifications and/or data in this document are provided for informational and illustrative purposes only and are not warranties of any kind. Product designs and/or specifications may be changed at any time without notice. Any applicable warranties that may be provided by Komatsu for the products and services are available on request.

Komatsu and other trade marks and service marks used herein are the property of Komatsu Ltd., Komatsu Australia Pty Ltd, Komatsu America Corp., Komatsu Mining Corp., or one of their affiliates, or the respective owners or licensees.

KOMATSU

[komatsu.com.au](https://www.komatsu.com.au)

[komatsu.co.nz](https://www.komatsu.co.nz)

