

KOMATSU

PC25MR-5

EPA Tier 4 Final Engine
Australia and New Zealand Specifications



Photo may include overseas specification

Compact
hydraulic
excavator

Horsepower
15.8 kW / 21.2 HP @ 2,500 RPM

Operating weight
2,750 kg
Approximately subject
to specification

Bucket capacity
0.035 - 0.085 m³

A user-friendly machine with **top class performance**



Workability

- Relocated swing cylinder
- Automatic travel speed change increases work efficiency and makes gear changes smoother

Safety first

- Compliant with ROPS (ISO 3471) and OPG top guard (ISO 10262) standards
- Travel alarm
- Engine shutdown secondary switch
- Seat belt caution indicator

First-class comfort

- Spacious and comfortable operator's compartment
- Multiple accessories around the operator's seat

Easy maintenance

- Fully opening engine door and side cover for easy maintenance
- 2-split floor mat
- Hydraulic oil filter
- Battery disconnect switch
- Large fuel filler port for easier fuel filling

Komtrax

- Komatsu Wireless Monitoring System
- 4G mobile communications
- Increased operational data and reports

Horsepower

15.8 kW / 21.2 HP @ 2,500 RPM

Operating weight

2,550 kg

Bucket capacity

0.033 - 0.09 m³

Workability



The photo shows Japan specification of PC25MR.

Travel lamp provided as standard

This travel lamp provides an increased visibility both in a night operation and in the travel position.



A boom cylinder guard

This design reduces damage to the cylinder caused by interference of the breaker, hitting against the dump vessel, etc.



Komatsu CLSS

The CLSS (Closed-Centre Load Sensing System) hydraulic circuit guarantees power, speed and perfect control to all movements, including simultaneous ones.

The combination of the variable displacement pump and of CLSS allows operators to perform all required movements with maximum efficiency, regardless of the load or rpm. The unique CLSS characteristics are perfectly complemented by the hydraulic servo-controls, which are, by far, the easiest to use and that allow extremely precise manoeuvres with minimal effort.

Automatic down-shift

Once turned on, this feature automatically adjusts the hydraulic travel motor for the job at hand : maximum displacement for faster movement, or minimum displacement for high drawbar pull. This process requires no attention from the operator. The two-speed tracking is operated via a switch on the blade lever.

Safety first

Two-Post ROPS and OPG canopy/cab

Canopy compliant with ROPS and OPG (Top Guard Level 1)

Equipped with two-post canopy with steel roof compliant with ROPS and OPG standard, and a retracting seat belt.

The cab model is also compliant with the ROPS and OPG (Top guard level 1) standards.

Note: Do not remove the canopy or cab, which is compliant with the following safety standards. Always wear the seat belt to secure your body to the protected area (Operator's seat) of the ROPS.

ROPS: Roll-Over Protective Structures
A mechanism to protect the operator with a seat belt in the event of rolling over Compliant under the test conditions of ISO 3471

OPG: Operator Protective Guards (Top guard)
A mechanism to protect the operator from falling objects Compliant with top guard level 1 of ISO 10262



Secondary engine shut down switch

Dual lock system engine shutdown secondary switch at base of seat is added to shutdown engine.



Built-in hydraulic hoses with protector

The hose joints between the arm and boom have been built in. The piping at the boom foot of MR-3 series is also built in to further heighten reliability.



Dual lock system

The dual lock system prevents the machine from being operated by the control levers and pedals touched when operator cancels the lock levers. Even after the lock levers are canceled, the control levers and pedals remain disabled unless the operator pushes the lock cancel switch.



Lock lever

Unlock switch

Seat belt caution

A warning indicator on the monitor appears when the seat belt is not engaged.

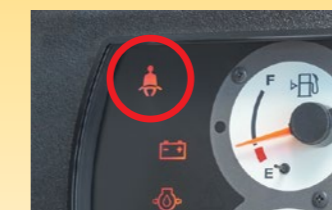

Other equipment

Reflector	Accumulator	Fan guard
Thermal guard	Travel alarm	

First-class comfort



An optimal work environment

Designed with the utmost attention to detail, the operator's environment offers outstanding comfort, accessibility and visibility. The wide entrance and well placed handholds allow easy entry and exit to and from the cab. Once seated, even the tallest operators have room to move their legs freely around the spacious, obstacle-free floor. For even greater comfort, an adjustable seat and PPC controls are fitted as standard.



Large cup holder provided as standard



12V external power outlet This power source outlet is a cigarette lighter socket which is the same as that of automobile.

Easy maintenance

Wide opening engine door and side covers operator compartment

Full-open cover for accurate and speedy daily inspection and major service.

The engine cover and large side covers can be swung open widely for accurate and speedy daily inspection. The rearranged layout of the hydraulic components allows access to every corner behind the covers for major service.

1. Alternator
2. Starting motor
3. Swing motor
4. Main valve
5. Hydraulic oil tank
6. Battery



The photo shows Japan specification of PC25MR.

Fuel filler port made easier to reach

The fuel filler port is now 30 cm lower than that of previous models. Refueling from a plastic fuel container is easier.



The photo shows Japan specification of PC25MR.

2-split floor mat

You can split the mat into two parts. This makes it easier to remove and clean the mat, and to wash the floor.



Long-life oil, filter

Long-life oil and a high-performance filter are used. The replacement interval for the engine oil and engine oil filter is 500 hours, and those for the hydraulic oil filter and hydraulic oil are 1000 hours and 2000 hours, respectively. These long replacement intervals reduce costs and contribute to effective use of resources.



Side-by-side cooling

Since radiator and after cooler are arranged in parallel, it is easy to clean, remove and install them.



Battery Disconnect Switch

For better safety during electrical circuit servicing.

Specifications

Engine

Model	Komatsu 3D76E-6
Type	Swirl chamber
Aspiration	Natural
Number of cylinders	3
Bore	76 mm
Stroke	82 mm
Piston displacement	1,115 L
Horsepower:	
SAE J1995	Gross 15.8 kW 21.2 HP
ISO 9249 / SAE J1349	Net 15.4 kW 20.7 HP
Rated rpm	2500 min ⁻¹
Fan drive method for radiator cooling	Mechanical
Governor	All speed control, mechanical

Hydraulic system

Type	Hydrau Mind system
Main pump:	
Type	Variable capacity x 1, gear x 2
Maximum flow	49.5 + 15.5 + 10.9 L/min
Hydraulic motors:	
Travel	Variable capacity x 2
Swing	Fixed capacity x 1
Relief valve setting:	
Implement circuits	24.5 MPa 250 kgf/cm ²
Travel circuit	24.5 MPa 250 kgf/cm ²
Swing circuit	20.6 MPa 210 kgf/cm ²
Pilot circuit	2.94 MPa 30 kgf/cm ²
Hydraulic cylinders:	
(Number of cylinders – bore x stroke x rod diameter)	
Boom	70 mm x 447 mm x 40 mm
Arm	65 mm x 451 mm x 40 mm
Bucket	55 mm x 460 mm x 35 mm
Boom swing	80 mm x 429.5 mm x 40 mm
Blade	70 mm x 135 mm x 35 mm

Drives and brakes

Steering control	Two levers
Drive method	Hydrostatic
Maximum drawbar pull	26.0 kN 2650 kgf
Maximum travel s	
High	4.0 km/h
Low	2.4 km/h
Service brake	Hydraulic lock
Parking brake	Mechanical disk brake

Swing system

Drive method	Hydraulic drive
Swing reduction	Planetary gear, single-reduction
Swing lock	Mechanical disk brake
Swing speed	8.9 min ⁻¹

Undercarriage

Track frame	X-frame
Number of track rollers each side	4

Coolant and lubricant capacity (refilling)

Fuel tank	28 L
Coolant	3.0 L
Engine	3.4 L
Final drive	0.6 L
Hydraulic tank	21 L

Operating weight (approximate)

Operating weight including one-piece boom with attachment piping, standard arm, standard bucket, blade, integrated counterweight, suspension seat, rated capacity of lubricants, coolant, full fuel tank, operator, and standard equipment.
 Operating weight: 2,750kg
 Ground Pressure: 0.28kg/cm²

Dimensions

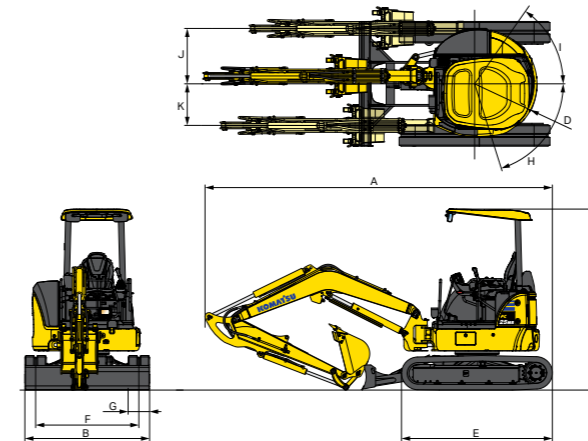

A Overall length	4,045 mm
B Overall width	1,500 mm
C Overall height	2,520 mm
D Tail swing radius	850 mm
E Crawler length	1,945 mm
F Track gauge	1,200 mm
G Shoe width	300 mm
H/I Boom swing angle	75° / 50°
J Bucket offset LH	510 mm
K Bucket offset RH	760 mm

Working range

Arm length	1370 mm
a Max. digging height	4340 mm
b Max. dumping height	3090 mm
c Max. digging depth	2720 mm
d Max. vertical wall digging depth	1760 mm
e Max. digging reach	4660 mm
f Max. digging reach at ground level	4530 mm
g Min. swing radius	2075 mm
Max. swing radius at boom swing	1645 mm

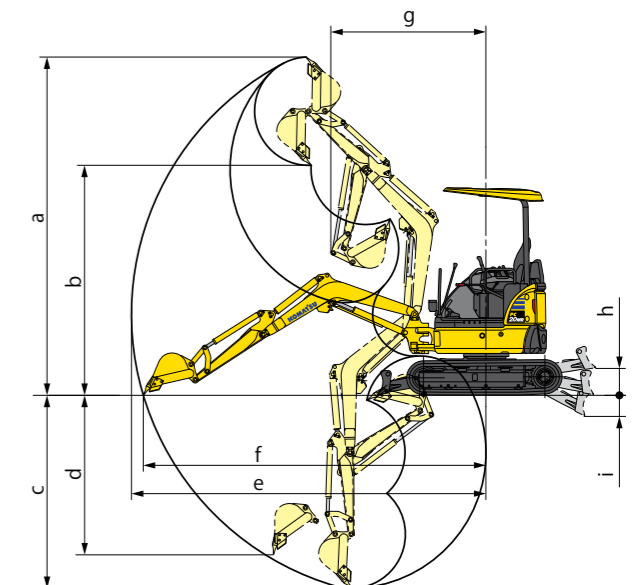

Lifting capacity

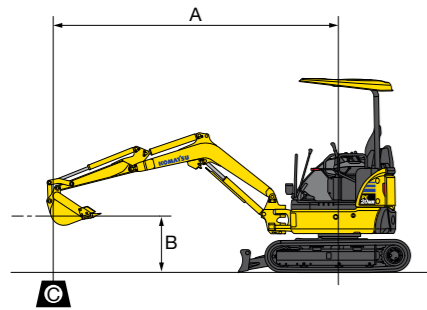

PC25MR-5

- A: Reach from swing center
- B: Bucket hook height
- C: Lifting capacity
- Cf: Rating over front
- Cs: Rating over side
- ☉: Rating at maximum reach

The illustration shows Japan specification of PC20MR.

	Arm length	2 m		3 m		4 m		
		Cf	Cs	Cf	Cs	Cf	Cs	
PC25MR-5	1115 mm	3 m	-	385 kg	385 kg	400 kg	400 kg	
		2 m	-	425 kg	425 kg	380 kg	300 kg	
		1 m	995 kg	760 kg	520 kg	410 kg	345 kg	270 kg
		0	950 kg	720 kg	500 kg	390 kg	365 kg	285 kg
		-1 m	960 kg	725 kg	500 kg	390 kg	475 kg	370 kg
	1370 mm	0	865 kg	680 kg	450 kg	365 kg	295 kg	240 kg

Standard equipment

Engine:

- Dry type air cleaner, double element
- Engine, Komatsu 3D76E-6
- Fuel filter (with water separator)
- Side-by-side cooling
- Wave fin radiator

Electrical system:

- Automatic two-speed travel control
- Battery disconnect switch
- Power supply, 1 x 12V

Hydraulic system

- Closed-center load sensing system
- Pressure Proportional Control (PPC)
- Boom stroke end cushion (RAISE side)
- Travel parking brake
- Swing parking brake

Guards and covers

- Thermal guard

Operator environment

- Rear view mirrors (RH, LH)
- High back air suspension seat
- Seat belt, retractable, 50 mm
- Engine shutdown secondary switch
- Seat belt caution indicator
- Dual lock system
- Accumulator
- Hose covers
- ROPS (ISO 3741) & Top guard canopy
- 2-split floor mat

Optional equipment

- Additional working light
- Radiator net
- Suspension seat, reclining with wrist rests
- Long arm

Product designs, specifications and/or data in this document are provided for informational purposes only and are not warranties of any kind. Product designs and/or specifications may be changed at any time without notice. The only warranties that apply to sales of products and services are Komatsu's standard written warranties, which will be furnished upon request.

Komatsu and other trademarks and service marks used herein are the property of Komatsu Ltd., Komatsu Australia Pty Ltd., Komatsu America Corp., Komatsu Mining Corp., or one of their affiliates, or the respective owners or licensees.

KOMATSU
[komatsu.com.au](https://www.komatsu.com.au)

