

KOMATSU®

WA1200-6

HORSEPOWER

Gross: 1411 kW 1892 HP / 1800 min⁻¹

Net: 1316 kW 1765 HP / 1800 min⁻¹

BUCKET CAPACITY

16.5–35.0 m³

WA
1200

WHEEL LOADER



Photo may include optional equipment.

WALK-AROUND

High Productivity & Low Fuel Consumption

UPGRADE

- The largest bucket in its class
- Extra dumping clearance and reach
- Hi-cab
- Remote boom positioner
- Selectable traction power
- High performance Komatsu SSDA16V160E-2 engine
- Low fuel consumption

See pages 4,5,6 and 7.

Excellent Operator Environment

- Automatic transmission with Electronically Controlled Modulation Valve
- Advanced Joystick Steering System
- Engine RPM set system with auto decel
- Variable transmission cut-off system
- Roomy, quiet cab with power windows
- Low vibration & noise
- Pillar-less large cab with ROPS/FOPS (ISO 3471/ISO 3449) canopy
- Comfortable operator's seat
- Trainer seat (optional)

See pages 10 and 11.



Harmony with Environment

- EPA Tier 2 emission certified
- Low fuel consumption

High Reliability & Durability

- Reliable Komatsu designed and manufactured components
- High-rigidity frames
- Low maintenance brake system
- Hydraulic hoses use flat face O-ring seals
- Cation electrodeposition process is used to apply primer paint
- Powder coating process is used to apply main structure paint
- Sealed connectors for electrical connections

See pages 8 and 9.

HORSEPOWER

Gross: 1411 kW 1892 HP / 1800 min⁻¹

Net: 1316 kW 1765 HP / 1800 min⁻¹

BUCKET CAPACITY

16.5–35.0 m³



Photo may include optional equipment.

Easy Maintenance

- Tire saver
- Long oil replacement interval
- Oil sealed loader linkage pins
- Centralized filter layout
- Quick fluid change-out system
- Auto-greasing system
- Equipment Management Monitoring System
- KOMTRAX Plus
- Maintenance accessibility
- Safety features
- Rear access stairs

See pages 12 and 13.

HIGH PRODUCTIVITY AND LOW FUEL CONSUMPTION

UPGRADE

The Largest Bucket in Its Class

Bucket line-up has been improved with adding new design bucket. And Lift capacity has been increased. It can achieve to improve productivity with reduction of number of passes. Komatsu bucket is designed for easy loading, little spillage and high fill factor. WA1200-6 outperforms the other loaders by Komatsu bucket with high traction and high breakout force.

Bucket capacities

Standard Boom	23.0 m³
High Lift Boom	21.5 m³ (optional)



Hi-cab

To enhance the loading performance when using larger buckets with the extra dumping clearance and reach, the hi-cab is standard equipment. From his vantage point, 6380 mm from the ground, the seated operator has a safe, unobstructed full view of the bucket and the inside of a 220-tonne truck body.

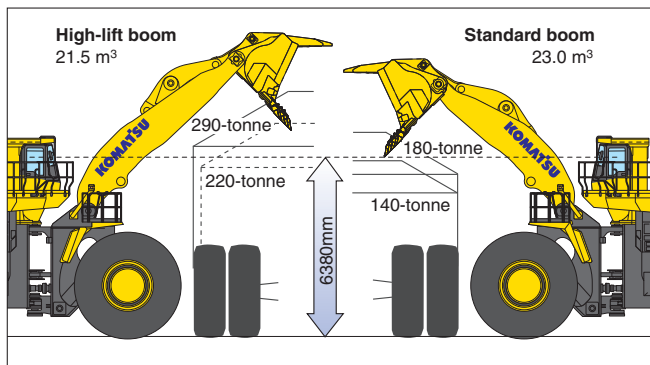

Boom	Bucket	Dump Clearance	Dump Reach
Standard Boom	23.0 m ³	6195 mm	3470 mm
High Lift Boom (optional)	21.5 m ³	6945 mm	3210 mm

Matching with Dump Trucks

Aggressive loading and maximum fill factors lead to exceptional productivity in the toughest mining conditions.

The WA1200-6 equipped with a 23.0 m³ bucket can load a 140-tonne truck in four passes. Due to its extra dumping clearance and reach it is able to load 180-tonne trucks in five passes. The high lift version can load 290-tonne plus trucks.

UPGRADE

Boom	Truck	140-tonne	180-tonne	220-tonne	290-tonne
Standard Boom		4 passes	5 passes	6 passes	—
High Lift Boom (optional)		—	5 passes	6 passes	8 passes

(In case of Specific gravity 1.8 / Bucket fill factor 95%)





High Performance Komatsu SSDA16V160E-2 Engine

Economical Komatsu SSDA16V160E-2 diesel engine provides power with reserve margins to move giant 23.0 m³ loads. Equipped with an electronic governor for low fuel consumption and electronic acceleration pedal and rpm set for easy operation.

Net power: 1316 kW 1765 HP

Max torque: 8.15 kN-m 831 kgf-m

Low Emission Engine

This engine is EPA Tier 2 emission certified without sacrificing power or machine productivity.

Low Fuel Consumption

Low fuel consumption is achieved because of the low-noise, high-torque engine and the large-capacity torque converter with maximum efficiency in the low-speed range.

High Breakout Force / Traction Force

Komatsu wheel loaders have high-tensile steel Z-bar loader linkages for maximum rigidity and maximum breakout force. Sealed loader linkage pins extend greasing intervals.

Breakout force:

1134 kN 115650 kgf

23.0 m³ Rock bucket (spade nose with teeth)

Traction force:

992 kN 101200 kgf

Excellent Stability

The WA1200-6 has the widest tread in its class 4,300mm and a long 7,100mm wheelbase, for maximum machine stability.

Static tipping load

(with 60/80 R57 tires / bucket 23.0 m³)

Straight: **114535 kg**

40° full turn: **100930 kg**



Remote Boom Positioner

The highest and lowest position of the bucket can be set from the operator's seat to match the height of any truck body. Where the positioner is set will stop the bucket smoothly without shock.

Selectable Traction Power and Travel Speed

- Maximum traction control:** Traction can be set at any level within 20 - 100% with the "TRACTION CONTROL DIAL" located on the left front. You can set the maximum traction force according to the condition of the road, material and type of work. It greatly increases fuel efficiency and extends the service life of tires.

- Maximum speed control:** With the "VEHICLE SPEED DIAL", you can set the maximum vehicle speed of 1st. and 2nd. at any level from 3km/h to max. This means the operator can set the cycle time between the material and the dump truck. As the loading cycle time is shortened, productivity is improved.



Dual-mode Active Working System

This system provides the most efficient hydraulic flow for your operation. The active working switch has two modes: powerful loading or normal loading.

Powerful loading mode

Digging / Scooping

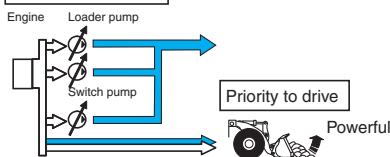

The driving force gets more power for digging and scooping material. The boom is raised faster for shorter cycle times. This combination makes this mode efficient for digging blasted rock or hard ground.

Raising the boom

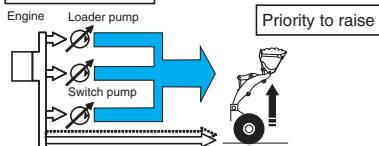

Normal loading mode

Always

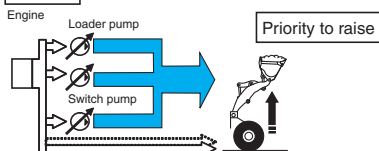

It does not cut off often, so the boom is raised faster. This mode is efficient for loading loose material that does not require traction force.



Pump Neutral Cut Control System for Hydraulic Pump

The variable displacement piston pump combined with the Pump Neutral Cut system, use only the required amount of oil flow for the work, so it does not waste oil pressure. This function reduces the fuel rate by controlling the pump discharge, when not operating the work equipment.

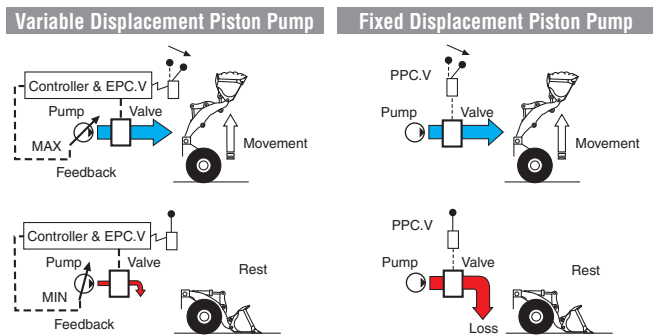

Modulated Clutch System

When approaching the dump truck,

- 1) The current system requires the engine rpm to be increased to raise the bucket faster. Now, the modulated clutch is controlled automatically to raise the bucket faster, while reducing forward travel speed. This reduction in travel speed eliminates the braking requirement and the time to approach the dump truck is shortened.
- 2) This combination also reduces torque waste and smooths the operation.

Variable Displacement Steering Pump + Closed-center load sensing system

The variable displacement steering pump, combined with the Closed-center load sensing system, delivers just the hydraulic flow the steering requires. This prevents wasted hydraulic pressure and contributes to increased fuel economy.

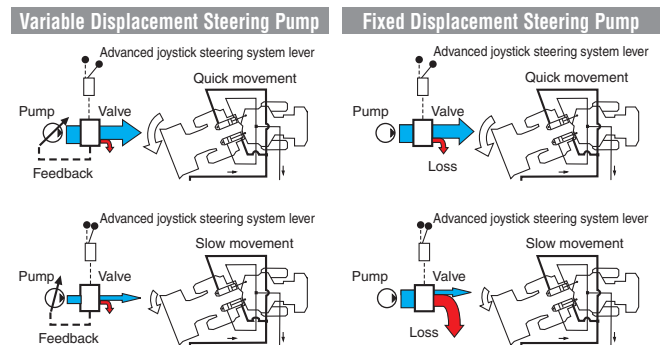

E ↔ P Control of Engine

The engine output function has "2 mode" of Economy or Power. They are selected and controlled automatically. P mode is selected only when digging and approaching the dump truck. This "2 mode" engine control contributes not only to the reduction of the fuel rate but also to the improvement of reliability and durability.

HIGH RELIABILITY & DURABILITY

Reliable Komatsu Designed and Manufactured Components

All components within the power train, from bolts to final gearing, are all Komatsu designed. Komatsu loaders are manufactured with an integrated production system under a strict quality control system.

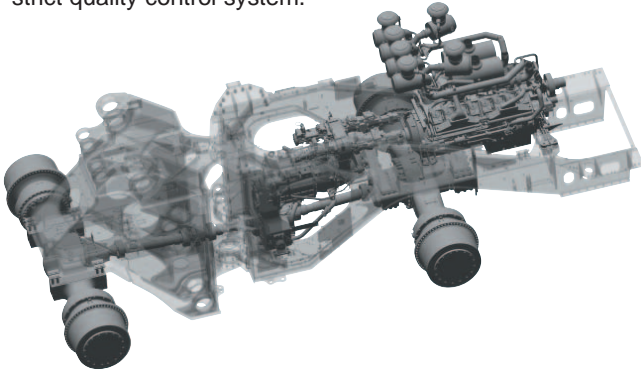

High-rigidity Frames and Loader Linkage

The front, rear frames and the loader linkage have increased torsional rigidity for stress resistance. Frame and loader linkage are designed and computer tested for proven strength to accommodate actual working loads.

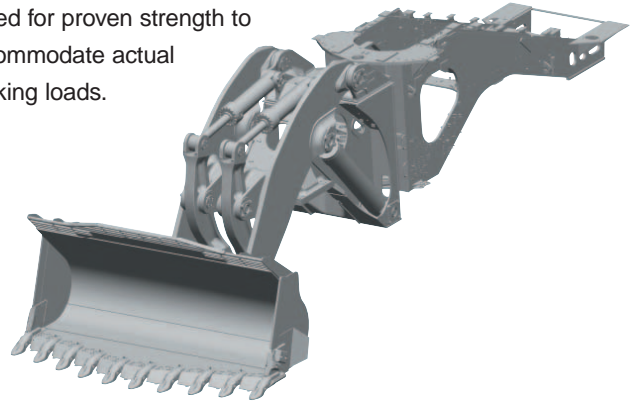

Engine Pre-lube System

Engine durability is achieved by raising the oil pressure before starting. When the key is turned, the pre-lubrication pump sends oil from the pan to the filter. When the set oil pressure is reached, then the starter motor engages to start the engine.

Low Maintenance Brake System

The WA1200-6 uses Komatsu designed sealed wet disc brakes. This proven design, coupled with a brake oil cooling system, provides reliable and durable final drive braking while downhill traveling with full loads and in all load and carry operations.



High-rigidity Frame

To increase frame reliability, steel castings have been incorporated at all pivot points to eliminate long weld lengths.



Sealed Connectors

Main harnesses and controller connectors are equipped with sealed connectors providing high reliability, dust and corrosion resistance.





Flat Face-to-face O-ring Seals

Flat face-to-face O-ring seals are used to securely seal hydraulic hose connections and to prevent oil leakage.

In addition, buffer rings are installed to the head side of the all-hydraulic cylinders to lower the load on the rod seals and maximize reliability.

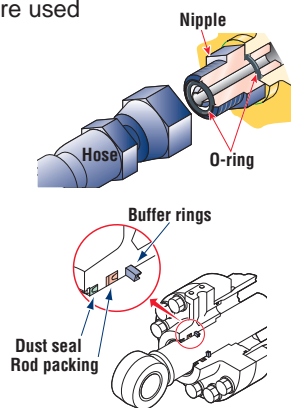

UPGRADE

Sweeper Wing (Large Size Tire Guard)

To prevent tire damage, the WA1200-6 provides a Sweeper Wing (large size tire guard) on both sides of bucket.

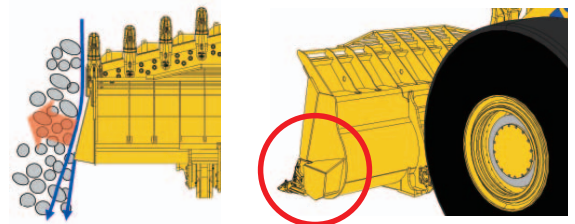

**Cation Electrodeposition Primer Paint/
Powder Coating Final Paint**

Cation electrodeposition paint is applied as a primer paint and powder coating is applied as topcoat to the exterior sheet metal parts. This process results in a durable paint finish, even in the most severe environments.

OPERATOR ENVIRONMENT

Easy Operation

Automatic Transmission with Electronically Controlled Modulation Valve

Automatic transmission with Electronically Controlled Modulation Valve automatically selects the proper gear speed based on travel speed, engine speed, and other travel conditions. The Electronically Controlled Modulation Valve engages the clutch smoothly to help prevent lag and shock when shifting. This system provides efficient machine operation for a comfortable ride.

● **Kick-down switch:**

Powerful scooping is available by shifting down to the 1st. speed, by pressing the kick down switch on the upper boom lever, when the lever is at the 2nd. position.

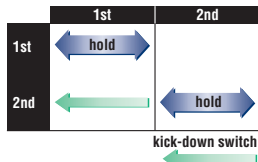

● **Vehicle speed control ON/OFF switch:** By turning the "Vehicle speed control ON/OFF switch" on the boom lever side to ON, the machine travels with vehicle speed limited to the maximum speed having been set with the "Vehicle speed control ON/OFF switch". When the "Vehicle speed control switch" is on, it is indicated by a light under the "Vehicle speed control dial".

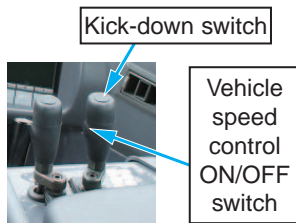

● **Transmission shifting switch:** Manual operation is available by shifting "Transmission shifting switch" to MANUAL. When traveling on a slope and you do not want to shift gears, you can select the appropriate gear.

Variable Transmission Cut-off System

Transmission cut-off position of the left brake pedal is optionally adjustable by switch operation at operator's seat. By adjusting the cut-off position according to the type of work, the inching operation becomes easy and increases efficiency.

- 1) When loading, adjust the cut-off pressure to low. Then the impact of braking is low to prevent spillage.
- 2) When traveling, adjust the cut-off pressure to high. Load applied to brake will be lighter by using engine brake while decelerating.



1:Transmission cut-off ON/OFF switch 3:Transmission shifting switch
2:Transmission cut-off set switch

Comfortable Operator's Seat

The operator's seat has a reclining/air suspension design with headrest to support the operator comfortably during long operation. Also, it is easy to adjust seat height with air suspension.



Advanced Joystick Steering System

Advanced Joystick Steering System is a feedback steering system which has been incorporated to allow steering, forward and reverse direction to be controlled by wrist and finger.

With the feedback function, the machine steering angle is exactly the same angle as the lever tilt angle.

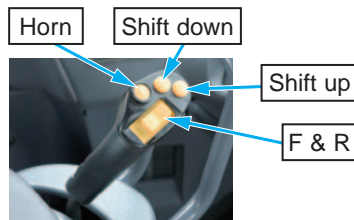

Engine RPM Set System with Auto Decel

Engine Low idle RPM can be easily preset using a push button switch. The system provides auto decel for better fuel consumption.

Trainer Seat (optional)

For operator instruction, a trainer seat is offered as an option. The seat belt is attached to the trainer seat the same way as the operator seat. The trainer seat can be folded up when not in use.

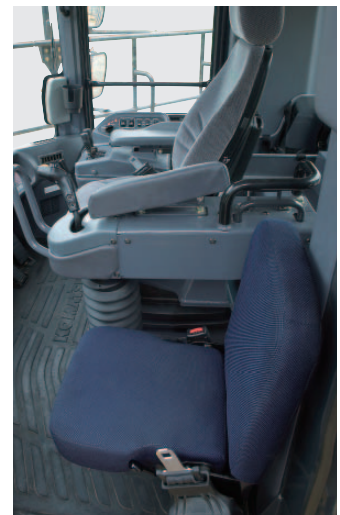

Comfortable Operation

Roomy, Quiet Cab with Power Windows

The cab is large, with a comfortably spacious interior and power windows. Also, a wide viewing angle is guaranteed because the cab is pillar-less. By adopting a high-capacity air conditioner, Komatsu ensures operator comfort, no matter the exterior conditions. Other features designed with operators in mind include a lunchbox storage space.



Lunchbox storage space

Low Vibration & Noise

The cab rests on Komatsu viscous damping mounts (rubber and silicon oil) to reduce vibration and noise.

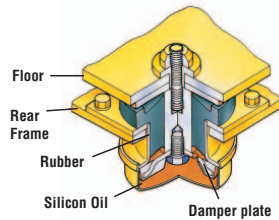

Overhead Panel

Controls for the AM/FM radio, window wiper and washer, cab lights, and air conditioner are all neatly arranged in an overhead console easily within the seated operator's reach.



Pillar-less Large Cab with ROPS / FOPS Canopy

A wide pillar-less flat glass provides excellent front visibility. The wiper arm covers a large area to provide great visibility even on rainy days.



ROPS (ISO 3471) : Roll-over Protective Structure
 FOPS (ISO 3449) : Falling Objects Protective Structure

Cab Air Conditioning

Large capacity air conditioning system combined with carefully placed vents provide optimum cool air flow. Defroster vents are designed to keep the rear window frost-free during cold weather operation. With a simple touch of his hand the operator can easily select from the five operating modes and four fan speeds on the overhead control panel.

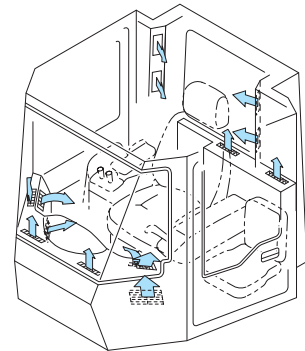

EASY MAINTENANCE

Tire Saver

The tire saver is quite effective for extending the service life of tires. It senses the tire that slips with a speed sensor, then controls the torque converter with the modulated clutch and stops the tire slip.



Fluid Drain from the Ground

Hydraulic oil, transmission/torque converter oil, engine oil, and engine coolant can all be changed from the ground. A fast-fill fuel system is also included as standard equipment.



Auto-greasing System

Except for the drive shaft, greasing is automatically done to the regular points with a preset amount and interval.

Long Oil Replacement Interval

Adoption of hybrid elements, that catch the fine and coarse contamination, has extended the interval between replacing elements.

Lubricated Pins for Loader Links

All of the loader links have lubricated pins, for much improved serviceability.

Centralized Filter Layout

Torque converter / transmission oil filters have been centrally located for ease of replacement from the ground.



Exhaust Heat Shields



Equipment Management Monitoring System

Monitor is mounted in front of the operator for easy viewing, allowing the operator to easily check gauges and warning lights.





Safety Features

- **Secondary brakes:**
If the brake oil pressure is too low, the parking brake is automatically engaged for accident prevention.
- **Secondary steering:**
If the steering pump is disabled, an emergency steering pump provides hydraulic flow.
- **Emergency engine stop switch:**
The stop switches that operation is possible from the ground are installed in four places and the inside of the cab.

Maintenance Accessibility

For safe maintenance operations, main points are equipped with a step and safety handrail.



Front frame steps



Rear frame steps

Rear Access Stairs

For safely boarding and exiting the machine, rear access stairs with a safety handrail are provided. The step width, clearance and angle have been designed for safety. The step angle has been reduced from 60 to 45 degrees. A step light provides light for night boarding. The emergency ladder is on the right side of the machine.



KOMTRAX Plus

KOMTRAX Plus is a management system for large mining equipment, which enables detailed monitoring of the fleet via satellite. Komatsu and distributors can analyze "vehicle health", other operating conditions and provide this information to the job site, using the Internet from a remote location, on a near-real time basis. As a result, customers receive timely vehicle maintenance, reduced maintenance expenses, downtime costs and avoid mechanical trouble.

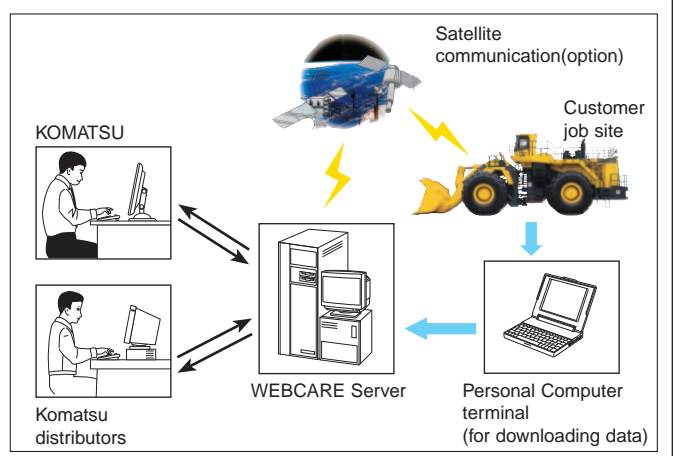

SPECIFICATIONS



ENGINE

Model Komatsu SSDA16V160E-2
 Type Water-cooled, 4-cycle
 Aspiration Turbocharged and aftercooled
 Number of cylinders 16
 Bore x stroke 159 mm x 190 mm
 Piston displacement 60.0 L
 Governor Electronic fuel control
 Horsepower
 SAE J1995 Gross 1411 kW 1892 HP
 ISO 9249/SAE J1349 Net 1316 kW 1765 HP
 Rated rpm 1800 min⁻¹
 Fan drive method for radiator cooling Mechanical
 Fuel system Modular common rail system direct injection
 Lubrication system:
 Method Screw pump, forced lubrication
 Filter Full-flow
 Air cleaner Dry-type with double elements and automatic dust evacuation with dust indicator on monitor
 EPA Tier 2 emission certified.



TRANSMISSION

Torque converter:
 Type 3-element, single-stage, single-phase
 Transmission:
 Type Full-powershift, planetary type with modulated clutch
 Travel speed: km/h
 Measured with 60/80 R57 tires

	1st	2nd	3rd
Forward	6.1	11.1	18.7
Reverse	6.3	11.4	19.3



AXLES AND FINAL DRIVES

Drive system Four-wheel drive
 Front Fixed, full-floating
 Rear Center-pin support, full-floating, 16° total oscillation
 Reduction gear Spiral bevel gear
 Differential gear Straight bevel gear
 Final reduction gear Planetary gear, double reduction, oil bath



BRAKES

Service brakes Hydraulically actuated, wet, multiple-disc brakes actuated on four wheels.
 Parking brake Wet, multiple-disc, hydraulically-released, spring applied in the transmission.



STEERING SYSTEM

Type Articulated type, full-hydraulic power steering
 Steering angle 40° each direction
 Turning radius outside corner of bucket and teeth 14505 mm



BUCKET CONTROLS

Control positions
 Boom Raise, hold, lower, and float
 Bucket Tilt-back, hold, and dump



HYDRAULIC SYSTEM

Rated capacity (discharge flow) @1800 engine rpm
 Loader pump 1018 L/min
 Steering pump 633 L/min
 Switch pump 633 L/min
 Relief valve setting 31.4MPa 320 kgf/cm²
 Control valves A double spool closed-center hydraulic valve and a steering valve combined with a demand valve to provide optimum flow.

Hydraulic Cylinders	Number of Cylinders	Bore	Stroke
Boom	2	360 mm	1835 mm
Bucket	2	300 mm	985 mm
Steering	2	225 mm	660 mm

Control positions:

Boom Raise, hold, lower, and float
 Bucket Tilt-back, hold, and dump
 Hydraulic cycle time (rated load in bucket)
 Raise 15.4 s
 Dump 3.3 s
 Lower (Empty) 5.3 s



ROPS / FOPS & CAB

Structure complies with ISO 3471 ROPS (Roll-Over Protective Structure) standards, as well as ISO 3449 FOPS (Falling Object Protective Structure) standards. The cab is mounted on viscous damping mounts and is well insulated.



SERVICE REFILL CAPACITIES

Cooling system 570 L
 Fuel tank 5100 L
 Engine 280 L
 Hydraulic system 1300 L
 Differential, final drive (each axle) 670 L
 Torque converter and transmission 350 L
 Brake oil 75 L
 Brake cooling 290 L



TIRES

Select proper tires based on job requirements.
 Standard rim size 47.00-57/5.0
 Standard tire size 60/80 R57



BUCKET SELECTION GUIDE

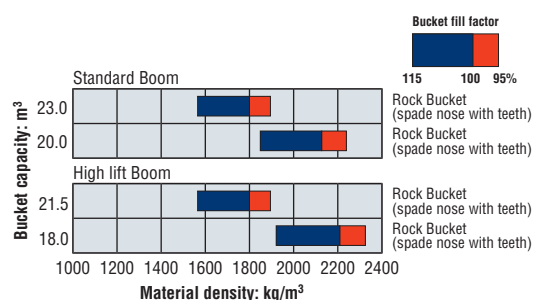

 DIMENSIONS

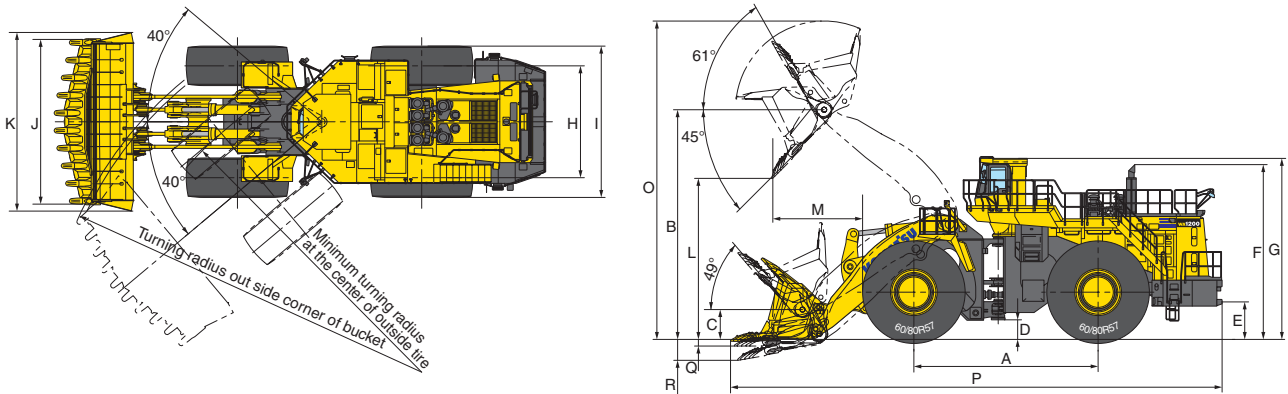

	Standard boom		High lift boom	
	60/80 R57	58/85-57-84PR	60/80 R57	58/85-57-84PR
H Tread	4300 mm	4300 mm	4300 mm	4300 mm
I Width over tires	5820 mm	5720 mm	5820 mm	5720 mm
A Wheelbase	7100 mm	7100 mm	7100 mm	7100 mm
B Hinge pin height, max. height	8850 mm	8855 mm	9535 mm	9540 mm
C Hinge pin height, carry position	1150 mm	1150 mm	1400 mm	1400 mm
D Ground clearance	760 mm	765 mm	760 mm	765 mm
E Hitch height	1415 mm	1420 mm	1415 mm	1420 mm
F Overall height, top of the stack	6735 mm	6740 mm	6735 mm	6740 mm
G Overall height, ROPS cab	6970 mm	6975 mm	6970 mm	6975 mm

	Standard boom				High lift boom			
	60/80 R57				60/80 R57			
	Rock Bucket Spade nose with teeth	Rock Bucket Spade nose with teeth	Rock Bucket Spade nose with teeth	Coal Bucket Spade nose without teeth	Rock Bucket Spade nose with teeth	Rock Bucket Spade nose with teeth	Rock Bucket Spade nose with teeth	Coal Bucket Spade nose without teeth
Bucket capacity (Heaped)	16.5 m ³	20.0 m ³	23.0 m ³	35.0 m ³	16.5 m ³	18.0 m ³	21.5 m ³	35.0 m ³
	(Struck)	13.7 m ³	17.2 m ³	19.1 m ³	30.2 m ³	13.7 m ³	15.0 m ³	17.7 m ³
Material density at 100% fill factor	2630 kg/m ³	2130 kg/m ³	1800 kg/m ³	1170 kg/m ³	2430 kg/m ³	2210 kg/m ³	1800 kg/m ³	1070 kg/m ³
J Bucket width	6400 mm	6400 mm	6400 mm	6400 mm	6400 mm	6400 mm	6400 mm	6400 mm
K Bucket width with tire protector	6555 mm	6555 mm	6880 mm	—	6555 mm	6555 mm	6880 mm	—
Bucket weight	22100 kg	22900 kg	24200 kg	24600 kg	22100 kg	22300 kg	23500 kg	24600 kg
L Dumping clearance, max. height and 45° dump angle	6740 mm	6335 mm	6195 mm	6310 mm	7420 mm	7155 mm	6945 mm	6985 mm
M Reach at max. height and 45° dump angle	3210 mm	3400 mm	3470 mm	3515 mm	3020 mm	3140 mm	3210 mm	3375 mm
O Operating height (fully raised)	11985 mm	12195 mm	12265 mm	12980 mm	12670 mm	12770 mm	12880 mm	13655 mm
P Overall length (bucket on ground)	18540 mm	18815 mm	18915 mm	18950 mm	18980 mm	19155 mm	19255 mm	19390 mm
Loader clearance circle *1	28690 mm	28920 mm	29010 mm	29020 mm	29090 mm	29240 mm	29320 mm	29465 mm
Q Digging depth: 0°	255 mm	255 mm	255 mm	145 mm	255 mm	255 mm	255 mm	145 mm
R 10°	755 mm	805 mm	820 mm	700 mm	755 mm	785 mm	805 mm	700 mm
Static tipping load: straight	116600 kg	115800 kg	114500 kg	114100 kg	105000 kg	104800 kg	103600 kg	102500 kg
	40° full turn	103000 kg	102200 kg	100900 kg	100500 kg	93100 kg	92900 kg	91700 kg
Breakout force	1323 kN	1178 kN	1134 kN	944 kN	1275 kN	1182 kN	1135 kN	944 kN
	135000 kgf	120200 kgf	115600 kgf	96200 kgf	130100 kgf	120600 kgf	115800 kgf	92600 kgf
Operating weight	216200 kg	217000 kg	218300 kg	218700 kg	218100 kg	218300 kg	219500 kg	220600 kg

*1 Measured with bucket at carry position, outside corner of bucket

All dimensions, weights, and performance values based on SAE J732c and J742b standards.

Static tipping load and operating weight shown include lubricant, coolant, full fuel tank, ROPS canopy, air conditioner, bucket and operator. Machine stability and operating weight are affected by counterweight, or ballast, tire size, and other attachments. Use either counterweight or ballast, not both. Apply the following weight changes to operating weight and static tipping load.



WEIGHT CHANGES

Tires or attachments	Operating weight	Tipping load straight		Tipping load full turn		Width over tires	Ground clearance	Change in vertical dimensions
		STD Boom	Hi-lift Boom	STD Boom	Hi-lift Boom			
	kg	kg	kg	kg	kg	mm	mm	mm
60/80 R57	0	0	0	0	0	5820	760	0
58/85-57-84PR	+820	+600	+540	+520	+470	5720	765	+5



STANDARD EQUIPMENT

- 2-spool valve for boom and bucket controls
- 6550 mm boom
- Alternator, 24 V/140 A
- AM/FM radio
- Air conditioner, heater, defroster & pressurizer
- Automatic greasing system
- Automatic transmission F3 / R3
- Axles, full floating
- Back-up alarm
- Back-up light
- Batteries, 6 x 12 V/160 Ah
- Battery disconnect switch
- Boom kick-out, automatic and adjustable
- Brakes:
 - Service: wet, multiple-disc
 - Parking: wet, multiple-disc
- Bucket positioner
- Cab with ROPS/FOPS (ISO 3471/ISO 3449) canopy
- Converter, 5 amps 12 volt
- Counterweight, standard
- Dualmode active working system
- Electromagnetic Proportional Control fingertip control levers with automatic leveler and positioner
- Electronic display/Multi Monitor
- Emergency engine stop switch
- Engine, Komatsu SSDA16V160E-2 diesel
- Fenders, front and left rear
- Floor mat
- Hard water area arrangement (corrosion resister)
- Horn, electric
- KOMTRAX Plus
- Lights
 - Backup light
 - Head lights (4 front)
 - Stop and tail
 - Turn signal with hazard switch (2 front, 2 rear)
 - Working lights (6 front, 8 rear)
 - Access stairs and service area light
- Load meter
- Power windows
- Rear access stairs
- Rearview mirror and rear underview mirror mounted to radiator guard
- Rims, 47.00-57/5.0
- Room mirror
- Seat belt, 76 mm with retractor
- Seat, air suspension with reclining
- Secondary brake
- Secondary steering (ISO 5010)
- Starting motor, 2 x 24 V/9.0 kW
- Steering, full hydraulic power (joystick steering control)
- Sun visor
- Tire saver (modulation clutch controlled)
- Vandalism protection kit
- Water separator
- Wiggins fast fuel fill
- Wiggins fast oil fill
- Wind washer, front and rear
- Wipers, front and rear, front intermittent



OPTIONAL EQUIPMENT

- Boom
 - 6900 mm boom
- Buckets
 - 23.0 m³ spade nose rock
 - 21.5 m³ spade nose rock (both with Hensley System)
 - 35.0 m³ coal
 - Various Hensley buckets
- Cold weather arrangement
- Fire extinguisher
- Front fender handrails
- Hensley large-scale teeth
- LED turn signal
- LED working lights
- Power train guard
- Radiator core protective grid
- Rear view monitor
- Rims
 - 44.00-57/6.0
 - 47.00-57/6.0
- Service center
- Trainer seat
- Yellow rotating lamp

<https://home.komatsu/en/>

Printed in Japan 201907 IP.SIN

KOMATSU®